



# Installation Guide

ExoTec™ and ExoTec™ Vero™  
Facade Panel and Fixing System

COMMERCIAL

**Australia** November 2019

**Make sure your information is up to date.**

When specifying or installing James Hardie™ products, ensure that you have the current technical information and guides. If in doubt, or you need more information, visit [www.jameshardie.com.au](http://www.jameshardie.com.au) or Ask James Hardie™ on 13 11 03.



## CONTENTS

1	INTRODUCTION	2
2	SAFE WORKING PRACTICES	3
	Warning	3
	Recommended safe working practices	3
	Working instructions	3
	Hole-forming	3
	Storage and handling	3
	Quality	3
3	INSTALLATION OVERVIEW	4
4	PRODUCT INFORMATION	5
	ExoTec™ facade panel	5
	Accessories/tools supplied by James Hardie	5
	Accessories/tools not supplied by James Hardie	5
5	PREPARATION	6
6	PANEL AND TOP HAT LAYOUT	7
7	INSTALLATION	8
	Top hat	8
	Panel	9
	Fastening methods - countersunk	10
	Fastening methods - exposed	11
	Backing strip installation	12
	Sealant filled joints	13
	Curved facades	13
8	MOVEMENT JOINTS	13
9	JUNCTIONS	14
	Base slab	14
	Head slab	15
	Soffit junction	15
10	EXTERNAL CORNERS	16
11	INTERNAL CORNERS	17
12	WINDOWS	18
13	PARAPET DETAILS	21
14	FINISHING	21
	General	21
	Panels exposed to direct sunlight	21
15	MAINTENANCE	22

# 1 INTRODUCTION

James Hardie's ExoTec™ facade panel provides a durable, expressed joint panel appearance for building facades and fascias and, together with the ExoTec™ fixing system, offers versatility to architects and builders. A variety of design styles can be created including curved walls, panels installed upright vertically, horizontally or in a brick pattern.

A wide range of decorative finishes can be used to the ExoTec™ Facade Panel including site-applied acrylic textures and available factory-applied polyurethane plain colours and metallic finishes.

Alternatively, use ExoTec™ Vero™ to achieve a natural concrete appearance and a fine sanded aesthetic. ExoTec™ Vero™ is pre-finished with a factory applied penetrating sealer on all six sides.

**NOTE:** ExoTec™ Vero™ cannot be painted on-site.

This document is a guide only. It is intended for use by builders, cladding installers and other contractors who may be involved with the installation of the ExoTec™ facade panel and fixing system.

This document must be read in conjunction with the project specific drawings and specifications as well as the current James Hardie ExoTec™ Facade Panel and Fixing System Technical Specification.

Both the 9mm and 12mm thick ExoTec™ facade panels may be used in wall facades, fascias and soffits.

#### **If you are an installer...**

Ensure that you follow the design, moisture management and associated details and material selection provided by the designer. This installation manual must be read in conjunction with the ExoTec™ Facade Panel Technical Specification.

#### **If you are a specifier...**

or other responsible party for a project, ensure the information in these specifications is appropriate for the application you are planning and that you undertake specific design and detailing for areas which fall outside the scope of these specifications.

#### **NOTE**

All dimensions shown are in millimetres unless noted otherwise. All Australian Standards referenced in this manual are current edition and must be complied with.

# 2 SAFE WORKING PRACTICES

## WARNING - DO NOT BREATHE DUST AND CUT ONLY IN WELL VENTILATED AREA

James Hardie™ products contain sand, a source of respirable crystalline silica which is considered by some international authorities to be a cause of cancer from some occupational sources. Breathing excessive amounts of respirable silica dust can also cause a disabling and potentially fatal lung disease called silicosis, and has been linked with other diseases. Some studies suggest smoking may increase these risks. During installation or handling: (1) work in outdoor areas with ample ventilation; (2) minimise dust when cutting by using either 'score and snap' knife, fibre cement shears or, where not feasible, use a HardieBlade™ Saw Blade (or equivalent) and dust-reducing circular saw attached to an appropriate, well maintained, M-class vacuum or greater with appropriate filter; (3) warn others in the immediate area to avoid breathing dust; (4) wear a properly-fitted, approved dust mask or respirator (minimum P1) in accordance with applicable government regulations and manufacturer instructions to further limit respirable silica exposures. During clean-up use a M-class vacuum or greater with appropriate filter, both of which are well maintained and appropriate for capturing fine (respirable) dust. Alternatively, use wet clean-up methods - never dry sweep. For further information, refer to our installation instructions and Safety Data Sheets available at [www.jameshardie.com.au](http://www.jameshardie.com.au). FAILURE TO ADHERE TO OUR WARNINGS, SAFETY DATA SHEETS, AND INSTALLATION INSTRUCTIONS MAY LEAD TO SERIOUS PERSONAL INJURY OR DEATH.

### JAMES HARDIE RECOMMENDED SAFE WORKING PRACTICES

#### CUTTING OUTDOORS

1. Position cutting station so wind will blow dust away from the user or others in working area.
2. Position the cutting station in a well-ventilated area. Use a dust reducing circular saw equipped with HardieBlade™ Saw Blade or comparable fibre cement blade and well maintained M-class vacuum or greater with appropriate filter capturing fine (respirable) dust.

#### CUTTING INDOORS

- Cut only using score and snap, hand guillotine or fibreshears (manual, electric or pneumatic).
- Position cutting station in a well-ventilated area.

#### DRILLING/OTHER MACHINING

When drilling or machining you should always wear a P1 or P2 dust mask and warn others in the immediate area.

#### IMPORTANT NOTES

1. For maximum protection (lowest respirable dust production) James Hardie recommends always using best practice cutting methods where feasible.
2. NEVER use a power saw indoors.
3. ALWAYS use a circular saw blade that carries the HardieBlade™ logo or is of at least comparable performance.
4. NEVER dry sweep - Use wet suppression, or an M class vacuum or greater with appropriate filter.
5. NEVER use grinders.
6. ALWAYS follow tool manufacturers' safety recommendations.

#### DUST MASKS AND RESPIRATORS

James Hardie recommends the use of P2 respirators as best practice. As a minimum, an AS/NZS1716 P1 respirator must be used when doing any activity that may create dust. For more extensive guidance and options for selecting respirators for workplaces please refer to Australian/New Zealand Standard 1715:2009 "Selection, Use and Maintenance of Respiratory Protective Equipment".

P1 or P2 respirators should be used in conjunction with the above cutting practices to minimise dust exposure. For further information, refer to Safety Data Sheet (SDS) available at [www.jameshardie.com.au](http://www.jameshardie.com.au). If concern still exists about exposure levels or you do not comply with the above practices, you should always consult a qualified industrial hygienist or contact James Hardie for further information.

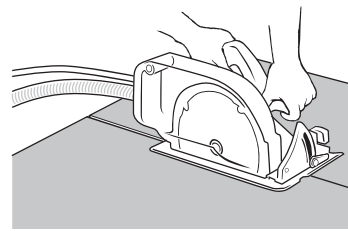
## WORKING INSTRUCTIONS

Refer to recommended safe working practices before starting any cutting or machining of product.

### HardieBlade™ Saw Blade

The HardieBlade™ Saw Blade used with a dust-reducing saw is ideal for fast, clean cutting of James Hardie™ fibre cement products. A dust-reducing saw uses a dust deflector or a dust collector which can be connected to a vacuum system. When sawing, clamp a straight-edge to the sheet as a guide and run the saw base plate along the straight edge when making the cut.

## HOLE-FORMING



### For smooth clean cut circular holes:

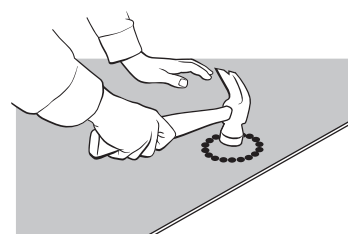
- Mark the centre of the hole on the sheet.
- Pre-drill a pilot hole.
- Using the pilot hole as a guide, cut the hole to the appropriate diameter with a hole saw fitted to a heavy duty electric drill.

### For irregular holes:

- Small rectangular or circular holes can be cut by drilling a series of small holes around the perimeter of the hole then tapping out the waste piece from the sheet face.
- Tap carefully to avoid damage to sheets, ensuring the sheet edges are properly supported.

## STORAGE AND HANDLING

To avoid damage, all James Hardie™ building products should be stored



with edges and corners of the sheets protected from chipping.

James Hardie™ building products must be installed in a dry state and protected from rain during transport and storage. The product must be laid flat under cover on a smooth level surface clear of the ground to avoid exposure to water, moisture, etc.

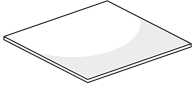
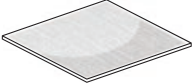
## QUALITY

James Hardie conducts stringent quality checks to ensure any product manufactured falls within our quality spectrum. It is the responsibility of the builder to ensure the product meets aesthetic requirements before installation. James Hardie will not be responsible for rectifying obvious aesthetic surface variations following installation.

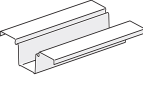
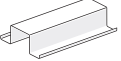
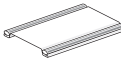
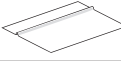


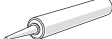

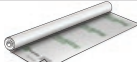


## IMPORTANT

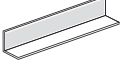








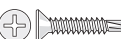

ExoTec™ Vero™ facade panels feature the natural colour and finish of fibre cement, and is subject to natural variations. James Hardie is not liable for any variation in look between ExoTec™ Vero™ facade panels or any variation in colour or surface pattern against any sample material provided. The architect/builder/installer must ensure prior to specification that variation in look between panels is acceptable and also ensure that each ExoTec™ Vero™ facade panel meets all aesthetic requirements prior to installation. For further information Ask James Hardie™ on 13 11 03.

# 3 PRODUCT INFORMATION

EXOTEC™ FACADE PANEL INFORMATION				
PRODUCT	DESCRIPTION	QUANTITY / SIZE (NOMINAL)		
	<b>ExoTec™ facade panel</b> Dense compressed panel. Square edge. Factory sealed on all six sides. Each panel has a distinctive white face, which accepts a wide range of paint finishes. The panel must be installed with the white side facing the exterior of the structure. Nom. density: 1550kg/m³	Thickness	Width	Lengths
		9mm	900mm 1200mm	1800, 2400, 3000 1800,2100 2400, 2700, 3000
	<b>ExoTec™ Vero™ facade panel</b> ExoTec™ Vero™ is pre-finished with a factory applied penetrating sealer on all six sides. Note: ExoTec™ Vero™ cannot be painted on-site. Nom. density: 1550g/m3	Thickness	Width	Lengths
		9mm	1200mm	2400, 3000

**NOTE:** Not all combinations of thicknesses, width and length are available ex stock, but are available to order. Check with James Hardie for availability of panel sizes.

PRODUCT / ACCESSORIES / TOOLS SUPPLIED BY JAMES HARDIE		
ACCESSORIES	DESCRIPTION	QUANTITY/SIZE (APPROX)
	<b>ExoTec™ Top Hat</b> A rolled metal section, for use with ExoTec™ facade panel and fixing system, designed to span vertically across the building structure to support facade panels and isolate differential movement of the panels from those of the structure. 124mm wide x 35mm deep x 0.75mm gauge thick. (Approximately)	45 per pack 6,000mm (305948) 7,200mm (305947)
	<b>James Hardie™ Intermediate Top Hat</b> A metal top hat installed vertically for use with ExoTec™ and ComTex® facade panel and fixing system, for intermediate sheet support. 50mm wide face x 35mm deep x 0.75mm gauge thick. (Approximately)	50 per pack 6,000mm (305950) 7,200mm (305949)
	<b>ExoTec™ Gasket Snap Strip. 3,620mm long</b> For use with the ExoTec™ facade panel and fixing system, this gasket snap strip is specially designed to clip into the ExoTec™ Top Hat at vertical facade panel joints to cover fixings to the structure and to provide an initial weather seal and drainage using a neoprene gasket.	10 per pack (305556)
	<b>James Hardie™ Backing Strip. 1,190mm, 2390mm, 2990mm</b> A weather seal at horizontal panel joints for use with ExoTec™ facade panel and fixing system and Scyon™ Matrix™ cladding.	10 per pack 1,190mm (305557) 2,390mm (305558) 2,990mm (305559)
	<b>James Hardie™ Facade Washers</b> Facade washers used for exposed fastener fixing with ExoTec™ facade panel and fixing system and Scyon™ Matrix™ cladding.	1000 per bag (305565)
	<b>James Hardie™ Base Coat. 4kg tub, 15kg bag</b> A water-resistant base coat compound used to finish over countersunk fasteners with epoxy.	4 per box - 4kg, 1 each - 15kg 4kg tub (305535) 15kg bag (305591)
	<b>James Hardie™ Joint Sealant, 300mL cartridge</b> A general purpose, paintable, exterior grade polyurethane joint sealant.	20 per box (305534)
	<b>RAB™ board</b> RAB is an all-in-one airtight, weatherproof, vapour permeable and non-combustible rigid 6mm fibre-cement sheathing for residential or commercial applications where the structural design require strong/stiffer shear walls.	45 per pack (305612)
	<b>HardieWrap™ weather barrier</b> A non-perforated, highly breathable and reflective safe-glare weather barrier designed to be used behind ExoTec™ facade panel and fixing system to help protect the building. Unit size 2750mm x 3000mm.	1 Each (305664)
	<b>HardieEdge™ Trim</b> An architectural slab edge solution fabricated from high-quality powder coated aluminium. Base Trim Unit size: 3950mm. 4 per pack. See right for all HardieEdge™ components:	Base Trim 4 per pack. (305911) Base Trim Joints 12 per pack. (305912) Internal Corner 12 per pack. (305913) External Corner 12 per pack. (305914)
<b>TOOLS</b>		
	<b>HardieBlade™ Saw Blade. 185mm diameter</b> A 185mm diameter poly-diamond blade for fast and clean cutting of James Hardie™ fibre cement.	1 Each (300660)

PRODUCT / ACCESSORIES / TOOLS NOT SUPPLIED BY JAMES HARDIE			
James Hardie recommends the following products for use in conjunction with ExoTec™ facade system. James Hardie does not supply these products and does not provide a warranty for their use. Please contact the component manufacturer for information on their warranties and further information on their products.			
ACCESSORIES	DESCRIPTION	ACCESSORIES	DESCRIPTION
	<b>Miscellaneous light gauge pressed metal section</b> Sections 1mm minimum to 1.2mm maximum corrosion resistant metal. Used in internal and external corner details.		<b>Flexible tape</b> A flexible self-adhesive tape used in preparation of a window. Refer to the window installation section in this Guide for more information.
	<b>Bond breaker tape</b> Used when filling vertical joints to prevent sealant from bonding to top hat. Refer to the ExoTec™ Facade Panel and Fixing System Technical Specification for suitable sealant.		<b>Base coat applicator</b> A recommended method of applying James Hardie™ base coat over epoxy filled countersunk screw heads. This method minimises waste. Base coat is easily sanded by comparison to epoxy fillers.
	<b>Vero™ Edge Sealer</b> Specialised touchup sealer used to re-seal site cut edges of James Hardie's ExoTec™ Vero™ facade panel. 250g bottle. Suitable for 48 sheets.		<b>Epoxy flush sealing (2 part)</b> Countersunk head screws are flush sealed using Megapoxy P1.
	<b>Countersunk head drill</b> 6mm countersunk bit.		<b>Clear Penetrating Sealer</b> Durable, external-grade penetrating sealer suitable for cement-based substrates. The following sealers have been tested and are recommended for resealing site cut edges: - Thompson's Water Seal - Crommelin Natural Finish sealer
	<b>6mm masonry drill</b> Provides a 6.2mm to 6.3mm diameter hole. Used to pre-drill clearance holes for fasteners.		
<b>FASTENERS</b>			
	<b>Countersunk fasteners</b> No. 10x30 countersunk head self drilling screws - Class 3 minimum coating.		<b>Exposed head fasteners</b> No. 10x25mm pan, wafer or hex head self drilling screws Class 3 Minimum coating.



# 4 DESIGN CONSIDERATIONS

## COMPLIANCE

All design and construction must comply with the appropriate requirements of the current Building Code of Australia (BCA), regulations and standards.

## SLAB AND FOOTINGS

The slab and footings on which the building is situated must be designed and certified by a qualified structural engineer according to all relevant codes, regulations and standards.

## GROUND CLEARANCES

Install James Hardie™ external cladding with a minimum 150mm clearance to the earth on the exterior of the building or in accordance with local building codes if greater than 150mm is required. Also, maintain a minimum 50mm clearance between James Hardie™ external cladding and roofs, decks, paths, steps and driveways.

Adjacent finished grade must slope away from the building in accordance with local building codes, typically a minimum slope of 50mm minimum over the first metre.

Do not install external cladding in areas where it may remain in contact with standing water or debris.

## MOISTURE MANAGEMENT

The ExoTec™ facade panel and fixing system acts as a weather shield. To achieve a particular level of weathertightness, the designer must determine the appropriate moisture management detailing for the project. The designer should consider the following matters when making that determination:

- It is the responsibility of the builders and designers to identify moisture related risks associated with any particular building design. It is the responsibility of the builder to ensure appropriate moisture management is provided during framed wall construction through effective use of flashings, sealants and vapour permeable membranes such as HardieWrap™ weather barrier, building wraps, vapour retarders and damp proof course. Before installing panels, all wall openings, penetrations, intersections, connections, window sills, heads and jambs must incorporate appropriate flashing and waterproofing. Materials, components and the installation practices that are used to manage moisture in framed wall construction must, at a minimum, comply with the requirements of relevant standards, building codes and the manufacturer's specifications.
- Sealant at sheet joints must be installed where detailed in this literature. For wind pressures up to 4.0kPa, see Clauses 6.2 and 6.3. For pressures including and above 4.0kPa, both vertical and horizontal joints must be sealant filled, see Clause 6.5. Refer to Clause 6.4 for suitable joint sealant. Where sealant is exposed, refer to the sealant manufacturer for durability information.
- For high walls it may be necessary to provide flashing to drain the facade at one or more intermediate levels.
- The installation of smoke, vermin and other barriers must not restrict moisture from reaching flashings.

## TOP HAT FRAMING

ExoTec™ facade panels must be fixed to ExoTec™ top hat and intermediate JH top hat sections which are installed vertically over steel, masonry or timber structures. See Figure 1. ExoTec™ top hat and intermediate JH top hat sections must not be installed horizontally. Ensure a planar fixing surface for ExoTec™ facade panels. The structure can either be straightened or packed out between the substructure and top hats. Packing out of top hats must be limited to 20mm maximum.

It is the responsibility of the project engineer to determine the appropriate wind pressures for the project and specify the fixing of the top hats to the structure. The engineer must limit the deflection of the supporting structure to span/250 for Serviceability Wind Load.

The nominal spacing between top hats is 605mm for a 1200mm wide panel and 455mm for a 900mm wide panel, i.e. top hats are required at panel edges and at intermediate spacings within the panels. The ExoTec™ top hats at panel edges have the legs facing out from the structure and at intermediate locations the intermediate JH top hat is used, with the legs fixed to the structure, see Figure 2.

The maximum spans and nominal spacings of ExoTec™ top hats and intermediate JH top hats for wall and soffit applications are provided in Tables 1 and 2 respectively, see page 4. For wall applications, the maximum cantilever distance of the top hats is one quarter of the single span shown in Table 1.

## SEALANT FILLED JOINTS

For design wind pressures including and above 4.0kPa, all horizontal and vertical joints must be continuously sealed over bond breaker tape.

Where joints are required to be sealant filled, James Hardie™ Joint Sealant and Bostik Seal 'n' flex are recommended. Where vertical joints are sealed, a bond breaker tape must be installed behind the sealant.

## CURVED FACADES

The ExoTec™ facade panel and fixing system can be used to follow curved walls as described below:

### For radii 10m or greater

Use 9mm thick ExoTec™ facade panels which can be easily bent to the curve of the frame. ExoTec™ facade panels are to be fixed in a horizontal orientation only. Refer to Table 4 for maximum top hat spacing.

TABLE 4

MAX. TOP HAT SPACING FOR VARIOUS RADII		
RADII (m)	MAX. TOP HAT SPACING (mm)	
	900mm wide panels	1200mm wide panels
10 to 15	300	400
>15	450	To suit wind loading

## NOTES

1. The closer the spacing of top hats, the less likely they will read through as facets in the panels, particularly at a small radii.
2. 9mm thick panels may be able to be curved to a smaller radius, but this is likely to overstress panels.

## NOTE

When fixing curved sheets, commence fixing from the centre and work outwards to avoid "drumminess".

Particular care should be taken when curving panels to ensure the supports are on a true curve. If not, apart from poor appearance, there is a risk of locally over-stressing the panels and causing cracking.

Alternate materials and installation methods are available for radii less than specified above including, glass reinforced cement (GRC) installed according to manufacturer's specifications.

For further information on curved facades contact James Hardie on 13 11 03.

# 5 PREPARATION

Prior to installation of the ExoTec™ facade panel and fixing system ensure that the required preparation steps have been followed, see Figure 2

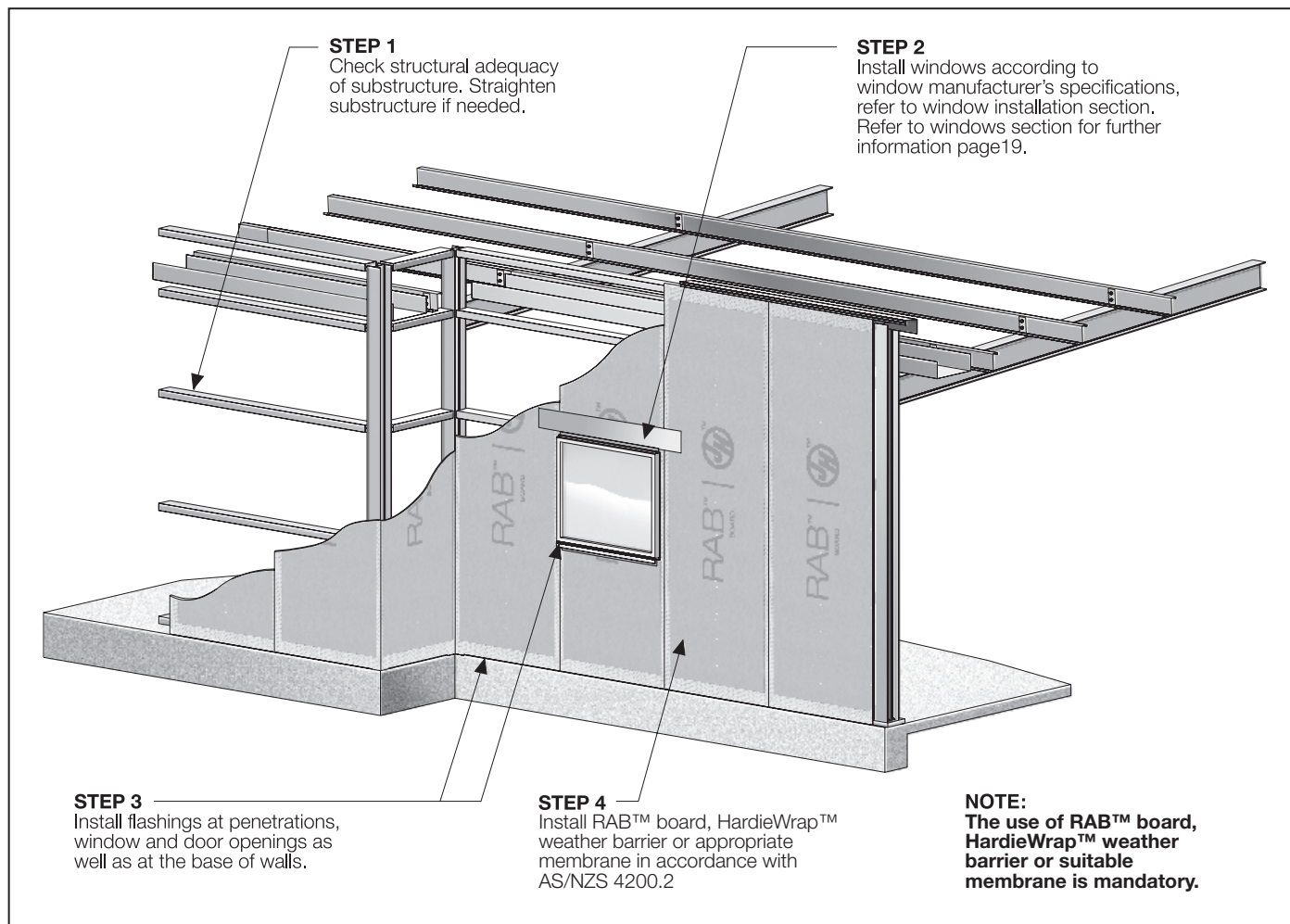


FIGURE 2 PREPARATION OF SUB-STRUCTURE

## NOTES

- For high walls it may be necessary to provide flashing to drain the facade at one or more intermediate levels. The installation of any barrier must not restrict moisture from reaching flashings and draining out.
- The engineer must limit the deflection of the supporting structure to span/250 for serviceability Wind Load. See Clause 2.6 of the ExoTec™ Facade Panel and Fixing System Technical Specification.

## Substructure

The ExoTec™ top hat and intermediate JH top hat sections are installed vertically over steel girts, masonry, concrete walling and in residential applications over timber or steel framing. In a residential application, noggings between studs can be used as intermediate support for ExoTec™ top hat and intermediate JH top hat sections.

A qualified structural engineer must design the substructure and the connection between the substructure and the top hats.

## Weather Barrier

A suitable water control membrane must be installed under James Hardie™ cladding in accordance with the AS/NZS 4200.2 'Pliable building membranes and underlays – Installation' and NCC requirements or other relevant and appropriate standards.

James Hardie has tested and certified the use of HardieWrap™ weather barrier or RAB™ board for climate zones 2-8 within Australia. HardieWrap™ weather barrier is a Class 4 vapour permeable membrane that delivers a triple-shield of protection to help against external weather penetration, internal condensation management and external heat penetration through its safe-glare reflective layer.

If using an alternate product in lieu of HardieWrap™ weather barrier or RAB board™ or the project is located in a hot humid area (Climate Zone 1), the designer must ensure that the product is fit for purpose and it has the following classification in accordance with AS/NZS 4200.1:2017 'Pliable building membranes and underlays – Materials':

HardieWrap™ weather barrier is suitable for use as a component of non-combustible walls and in bushfire prone areas as it has a "Low" Flammability Index in accordance with AS 1530.2 and is under 1mm in thickness.

WEATHER BARRIER CLASSIFICATION		
Climate Zones (NCC)	Water Barrier Class (AS/NZS 4200)	Vapour Permeance Class (AS/NZS 4200.1)e
2-8	High Water Barrier	Vapour permeable (Class 3 or 4)
1		Vapour Barrier (Class 1 or 2)

Soft compressible insulation installed between the front of the wall studs and directly behind the external cladding can cause installation issues and is thus not recommended.

# 6 PANEL AND TOP HAT LAYOUT

The ExoTec™ and ExoTec™ Vero™ facade panels can be installed upright horizontally or vertically. The panel layout will determine the location of the ExoTec™ and intermediate JH top hats, see Figures 3 to 6. The vertical expressed joints may be aligned or offset in a brick pattern layout.

## KEY

TH: ExoTec™ top hat

INT: Intermediate JH top hat

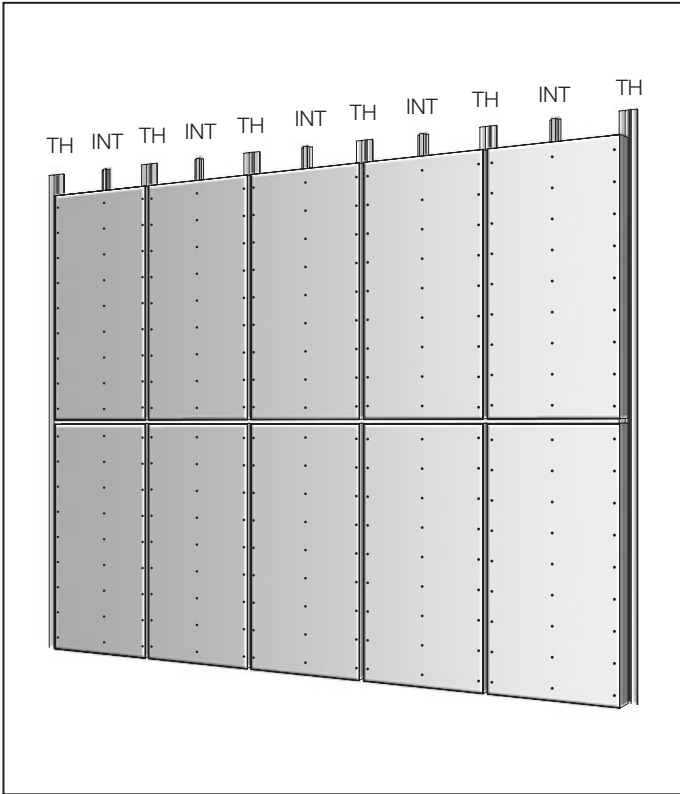


FIGURE 3 VERTICAL LAYOUT ALIGNED GRID PATTERN

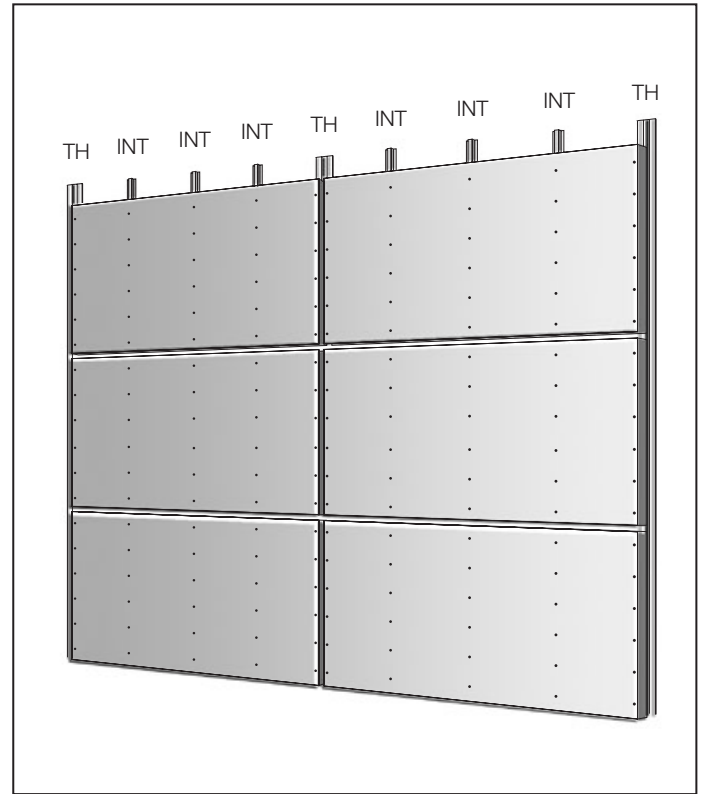


FIGURE 5 HORIZONTAL LAYOUT ALIGNED GRID PATTERN

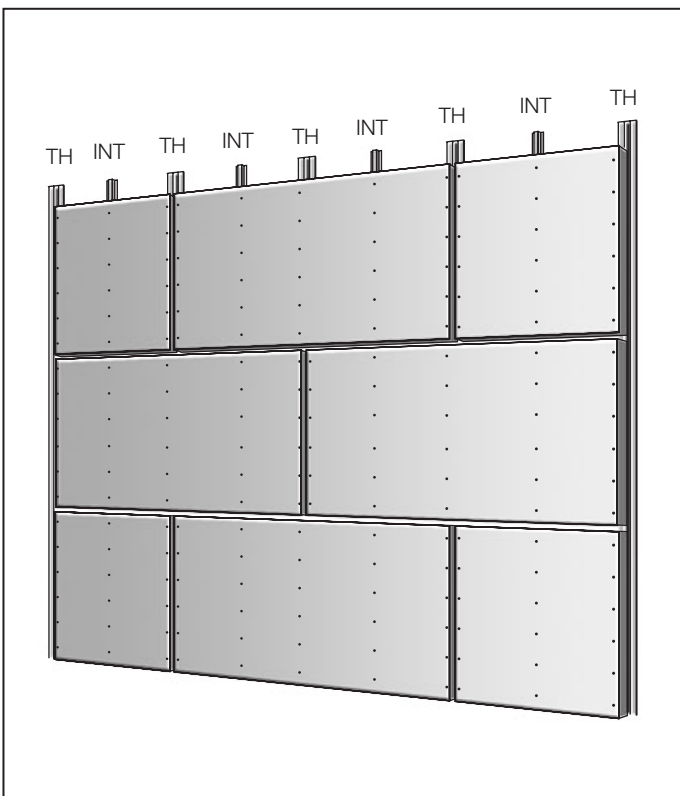


FIGURE 4 HORIZONTAL LAYOUT BRICK GRID PATTERN

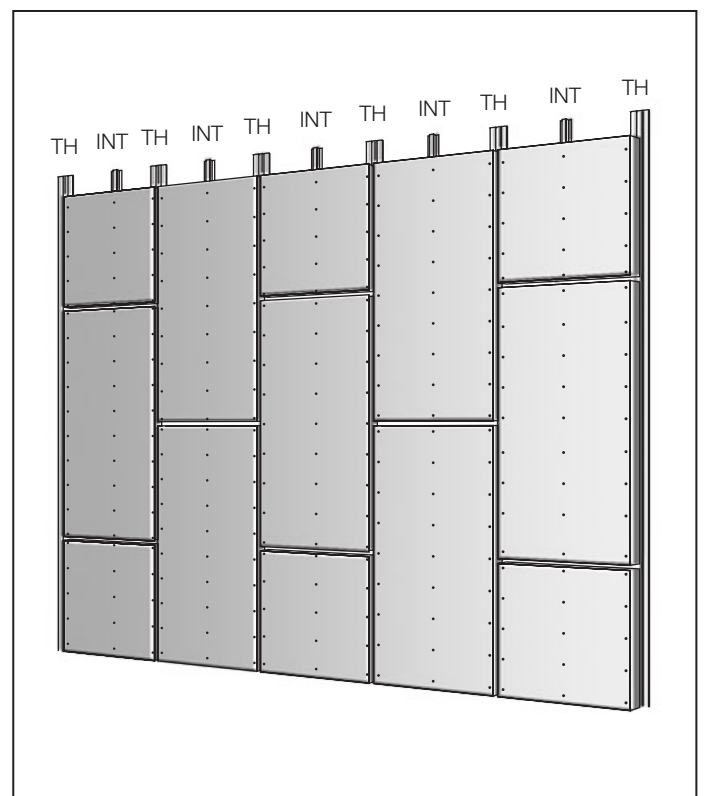


FIGURE 6 VERTICAL LAYOUT BRICK GRID PATTERN

# 7 INSTALLATION

## TOP HAT INSTALLATION

ExoTec™ facade panels must be fixed to:

- 1) ExoTec™ top hat for vertical sheet joints.
- 2) Intermediate JH top hat for supporting the panels between vertical sheet joints.

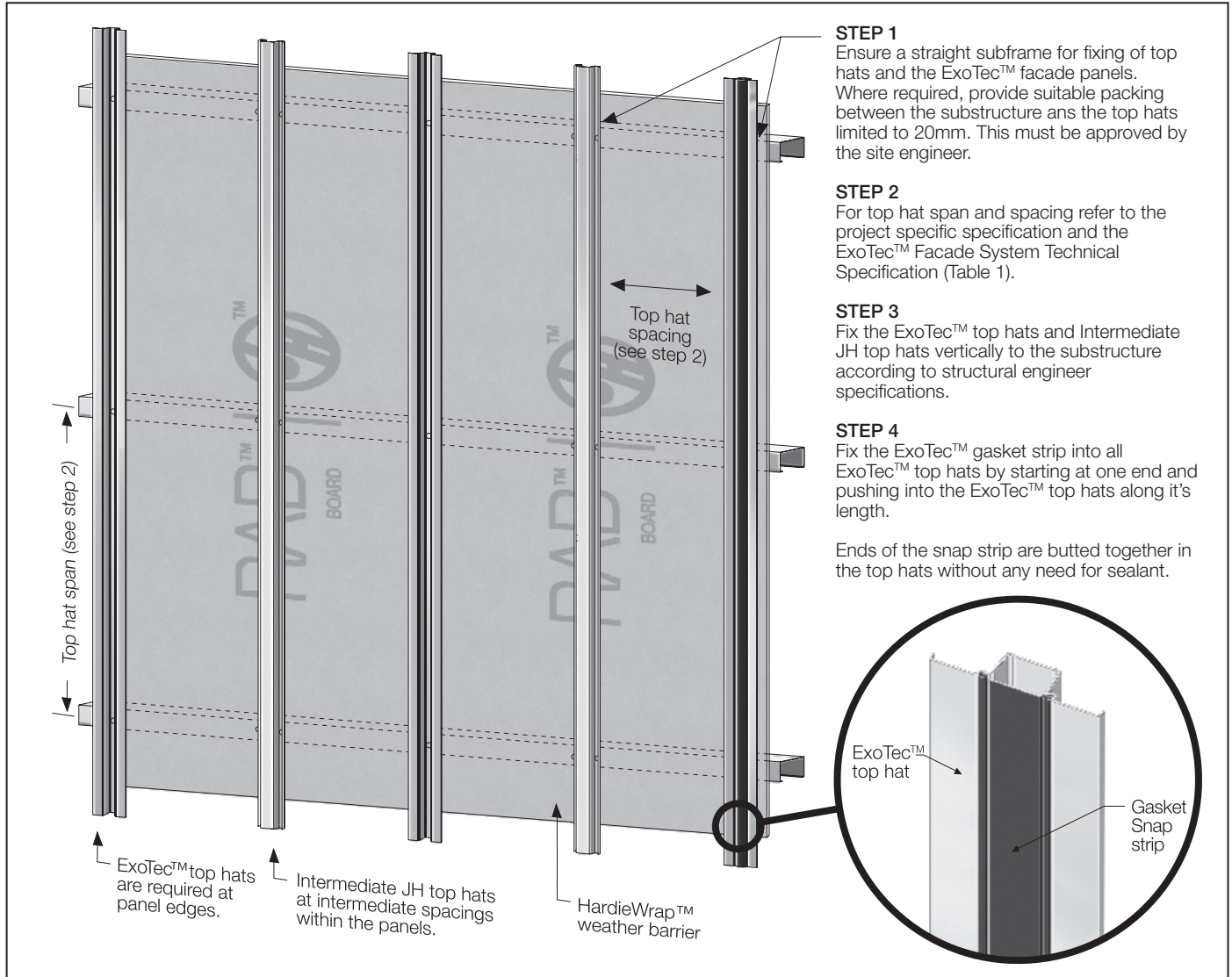


FIGURE 7 TOP HAT INSTALLATION

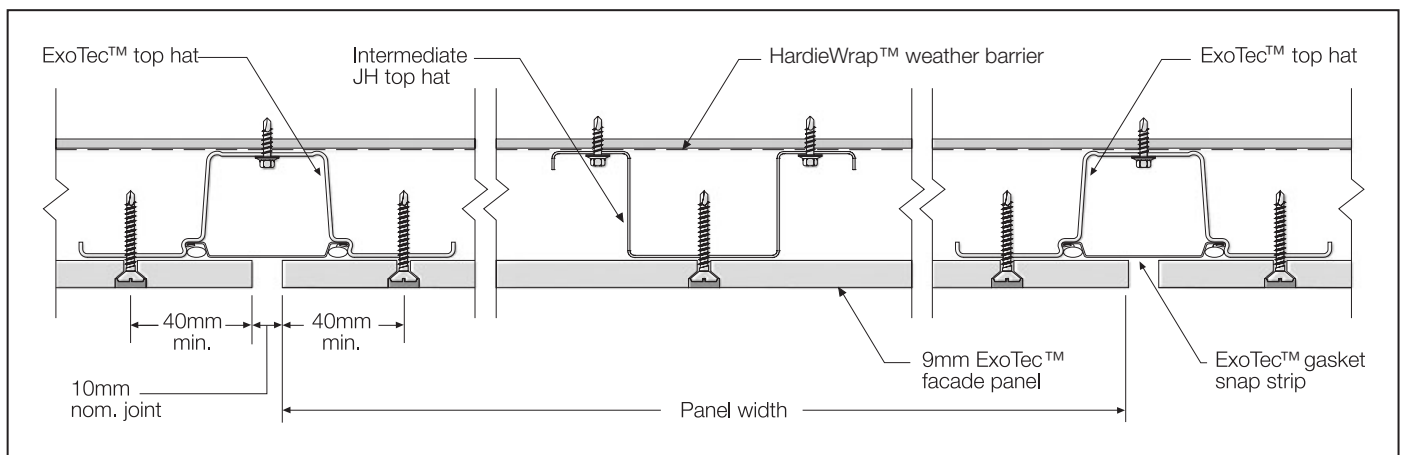


FIGURE 9 TOP HAT AND PANEL FIXING DETAIL FOR EXOTEC™ PANELS



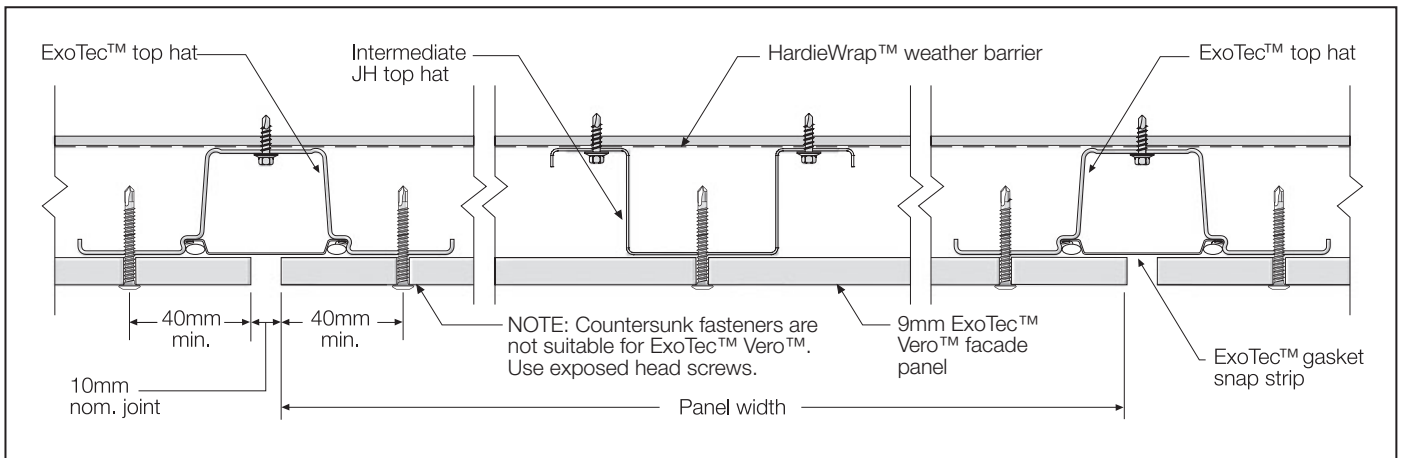


FIGURE 9 TOP HAT AND PANEL FIXING DETAIL FOR EXOTEC™ VERO™ PANELS

**PANEL INSTALLATION**

Panels are installed with a 10mm nominal expressed joint between adjacent panels, vertically and horizontally. Vertical joints up to 20mm width can be formed, with additional care required at installation to ensure the panel edges cover the ExoTec™ gasket snap strip on both sides of the joint. A minimum vertical expressed joint of 6mm is allowed with care. Horizontal joints are a nominal 10mm.

**NOTE**

When applying sealant to the edge of the ExoTec™ facade panel, refer to page 13 for recommended sealants.

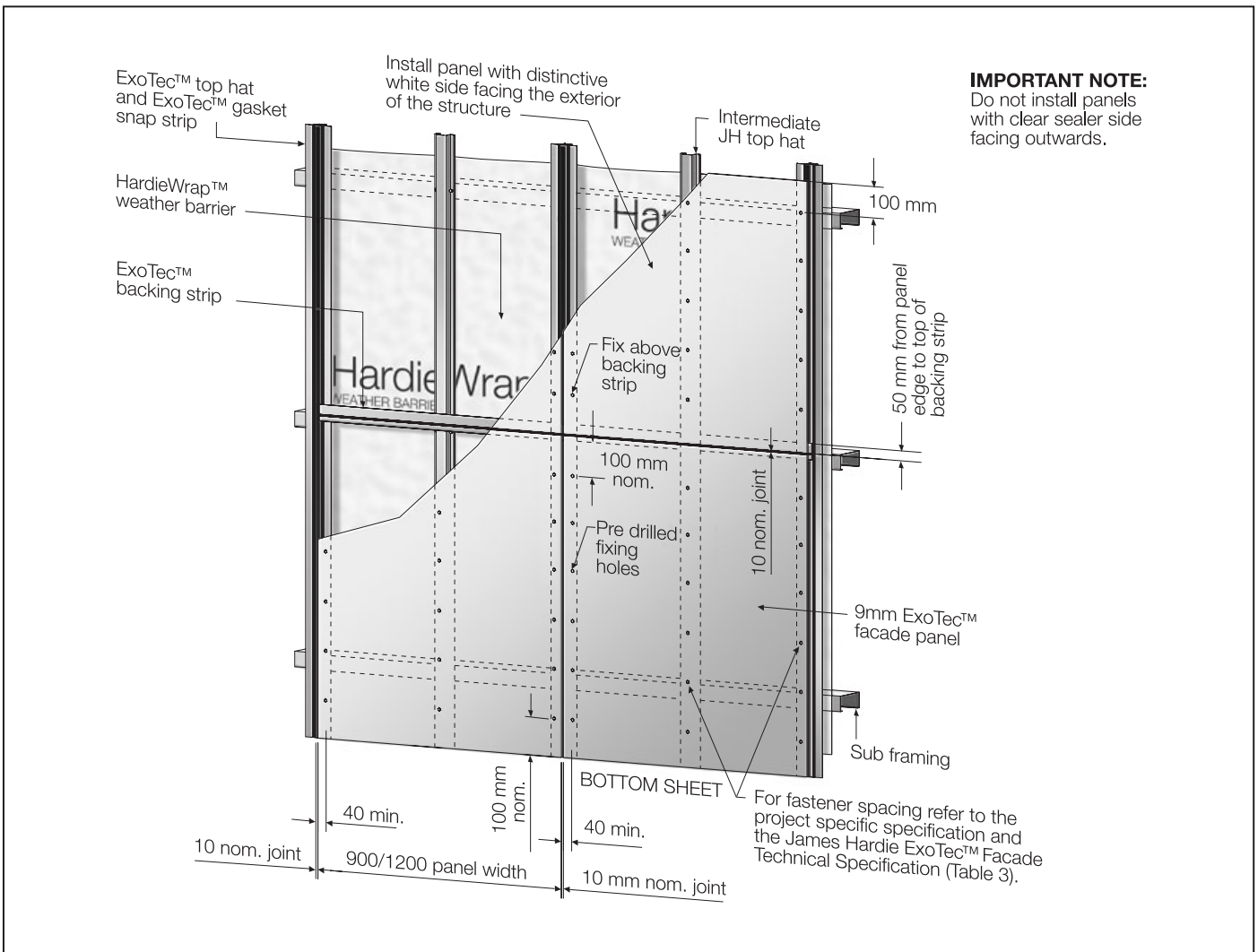


FIGURE 8 TYPICAL PANEL AND FRAMING LAYOUT

## 2.7 FASTENER SPACINGS

Table 3 indicates the maximum fastener spacings at sheet edges and at intermediate JH top hats for wall and soffit applications.

**TABLE 1 - WALLS & SOFFIT**

FASTENER SPACINGS (9mm AND 12mm THICK PANELS) FOR WALL AND SOFFIT APPLICATION			
Design Wind Pressure (kPa)	Top Hat Spacing (mm)	WALLS	SOFFITS
		Max. Fastener Spacing (mm)	Max. Fastener Spacing (mm)
1.0	600	600	600
1.5	600	600	600
2.0	600	575	550
2.5	600	450	425
3.0	600	350	350
3.5	*600	350*	N/A
3.5	450	450	425
4.0	450	400	375
4.5	450	350	325
5.0	450	300	300
5.5	450	275	275
6.0	450	250	250
6.5	400	250	250
7.0	400	250	250

### NOTES TO TABLES 1, 2 AND 3

1. Top hat deflection for serviceability limit state design to AS 1170.2 is limited to span/250, except where \* is shown it is span/180.
2. Design wind pressures to be in accordance with AS 1170.2 for ultimate strength design.
3. For permissible design wind pressure, divide the ultimate strength design wind pressures by 1.5.
4. For higher design wind pressures (ultimate), contact James Hardie on 13 11 03.

## FASTENING METHODS

Panels may be fixed to ExoTec™ top hats and intermediate JH top hats by either:

1. **Countersunk fasteners:** flush finished over screw heads with a suitable epoxy, and then with James Hardie™ base coat. Generally used with site-applied acrylic coatings. **NOTE:** Countersunk fastening is not suitable for ExoTec™ Vero™, and other pre-finished facade panels.
2. **Exposed head screws:** using pan, wafer or hex head screws. Used where pre-finished panels are installed. Exposed head fasteners may be colour coated to match panel finish.

Fasteners must have the appropriate level of durability required for the intended project. This is of particular importance in coastal areas, subject to salt spray and other corrosive environments.

Fasteners must be fully compatible with all other materials that the fasteners will come in contact with, to ensure the durability and integrity of assembly.

See Tables 3 and 4, for maximum fastener spacings to top hats for design wind pressure in the current ExoTec™ Facade Panel and Fixing System Technical Specification.

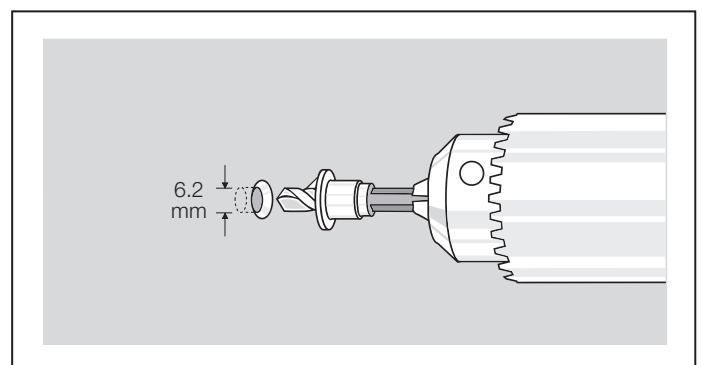
Contact fastener manufacturers for more information.

### Countersunk Fasteners

#### NOTE:

Countersunk fasteners are **not** suitable for ExoTec™ Vero™ Facade Panels. Use exposed head screws.

1. Mark fastener locations as specified, see Figure 8.
2. Drill clearance holes into ExoTec™ facade panel, for No.10 gauge screws using a 6mm countersunk masonry drill, which provides a 6.2 to 6.3mm diameter hole, see Figure 10. Countersink hole to a depth of 2.5mm to 3mm. This is measured from the top of the screw to the top of the sheet, see Figure 15.

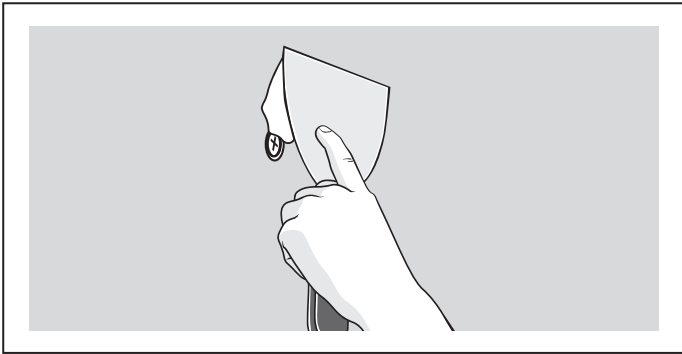


**FIGURE 10 DRILL COUNTERSINK HOLE**

#### NOTE:

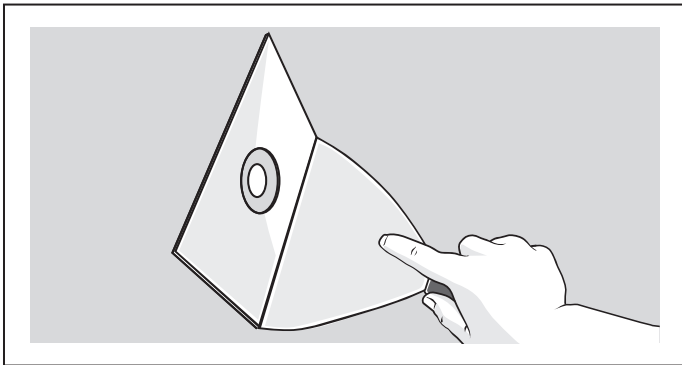
Do not use hammer action.

3. Fasten panel into top hat with corrosion resistant (Class 3 min.) No. 10 gauge x 30mm countersunk head self drilling fasteners. For areas within a corrosive environment refer to fastener manufacturer for suitability and compatibility of fasteners.
4. Clean dust out of holes to ensure adhesion of epoxy sealer.
5. Mix only sufficient epoxy for immediate use. James Hardie recommends the use of Megapoxy P1.
6. Cover countersink fastener with epoxy leveled flush with sheet. To accommodate for second coat do not overfill hole. Allow epoxy to cure.

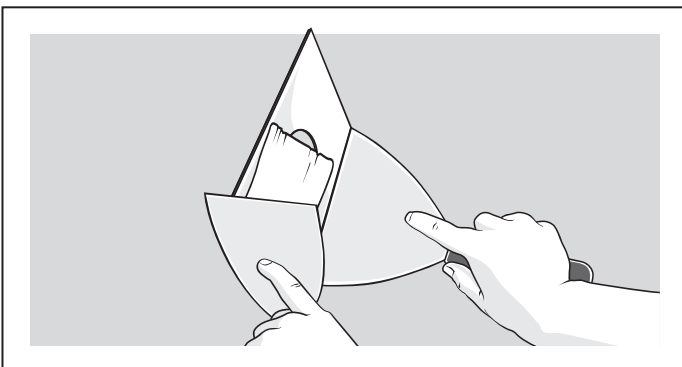


**FIGURE 11 COVER COUNTERSINK FASTENER WITH EPOXY**

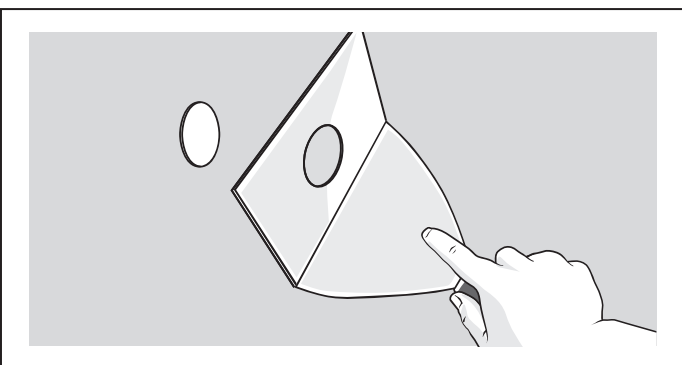
7. Apply James Hardie™ base coat over epoxy using the base coat applicator. See Figures 12, 13, and 14.



**FIGURE 12 FIX BASE COAT APPLICATOR OVER EPOXY FILLED SCREW HEAD**

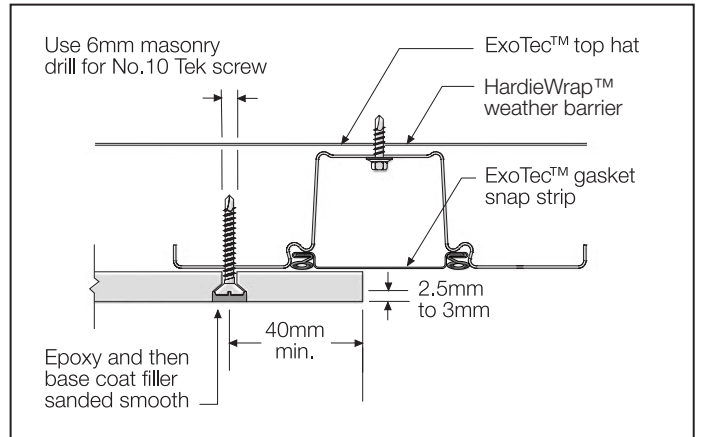


**FIGURE 13 APPLY JAMES HARDIE™ BASE COAT OVER EPOXY FILLED SCREW HEAD**



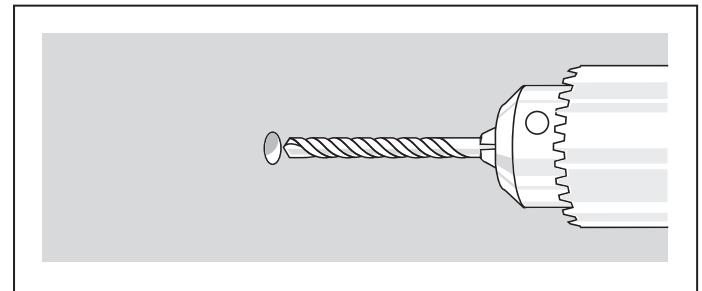
**FIGURE 14 SCREW HEAD COVERED BY EPOXY AND JH BASE COAT**

8. Sand James Hardie™ base coat smooth when cured with 100-120 grit sandpaper.

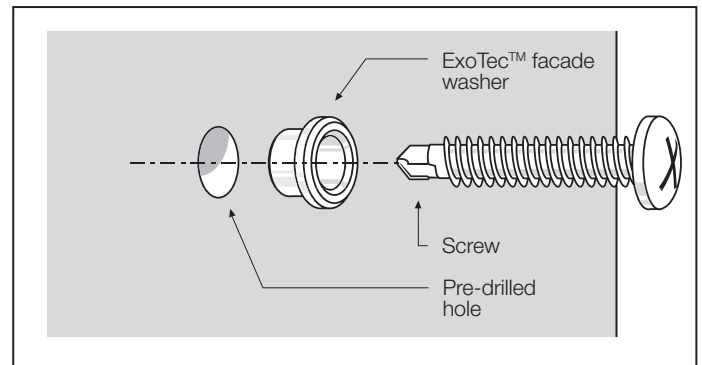


**FIGURE 15 COUNTERSUNK FASTENER DETAIL**

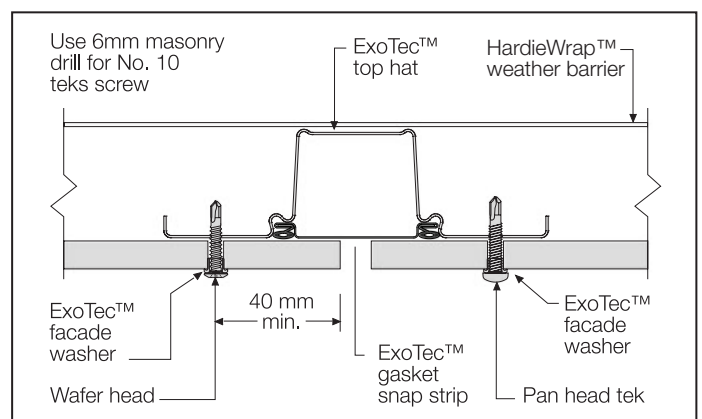
Do not use hammer action.



**FIGURE 16 DRILL CLEARANCE HOLE**



**FIGURE 17 WASHER AND SCREW INSTALLATION**



**FIGURE 18 EXPOSED HEAD FASTENER DETAIL**

## BACKING STRIP INSTALLATION

At horizontal panel joints, ExoTec™ backing strips are adhered along the back top edge of the ExoTec™ facade panel prior to panel installation.

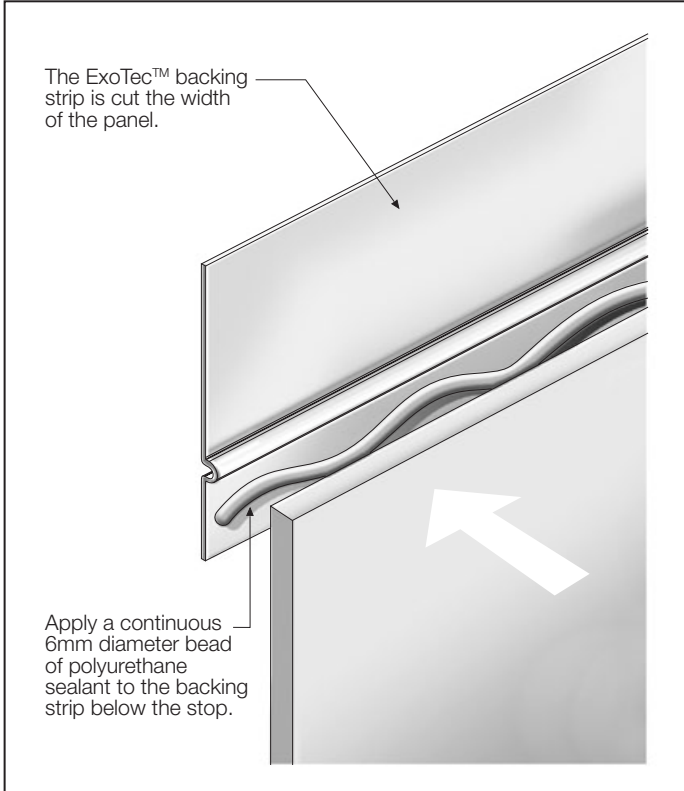


FIGURE 19 APPLYING SEALANT TO EXOTEC™ BACKING STRIP

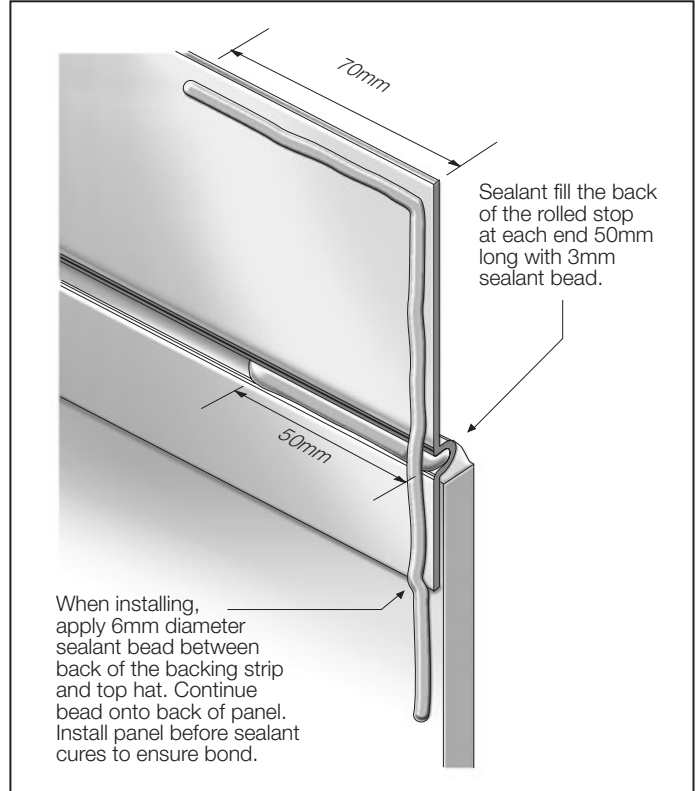


FIGURE 21 SEALING EXOTEC™ BACKING STRIP END DETAIL

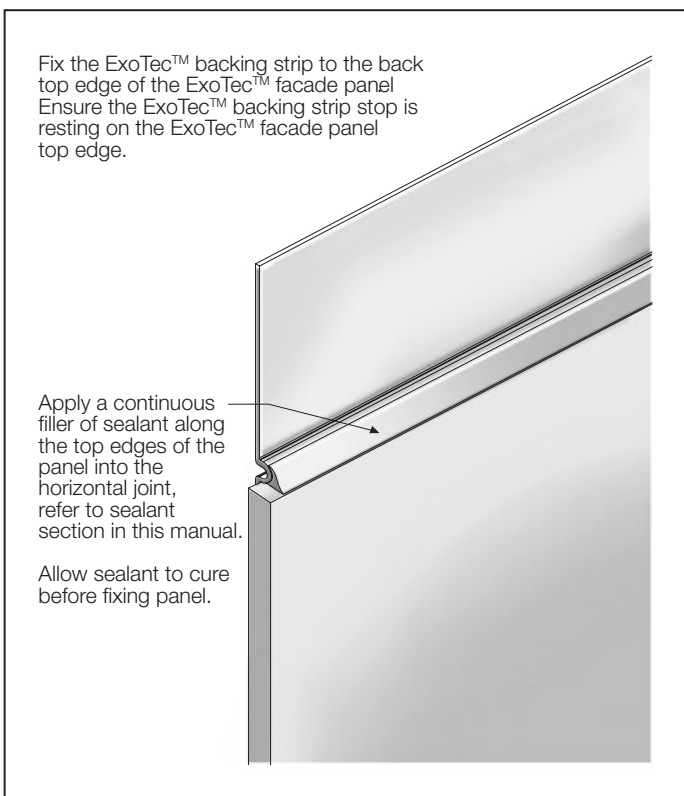


FIGURE 20 APPLYING SEALANT TO HORIZONTAL JOINT

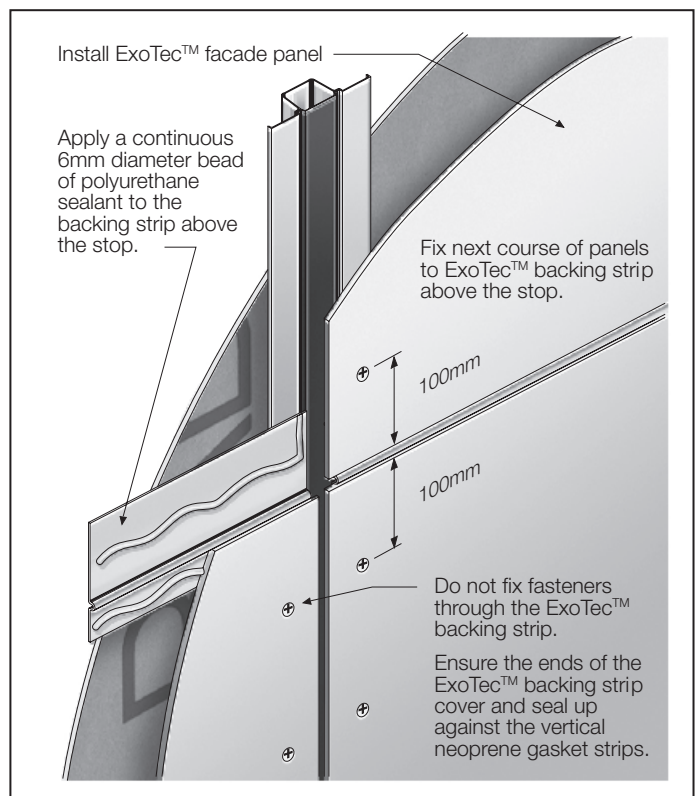


FIGURE 22 INSTALLING NEXT COURSE OF PANELS DETAILS



# 8 MOVEMENT JOINTS

## SEALANT FILLED JOINTS

For design wind pressures including and above 4.0kPa, all horizontal and vertical joints must be continuously sealed over bond breaker tape.

Where joints are required to be sealant filled, James Hardie™ Joint Sealant and Bostik Seal 'n' flex are recommended. Where vertical joints are sealed, a bond breaker tape must be installed behind the sealant.

## CURVED FACADES

The ExoTec™ facade panel and fixing system can be used to follow curved walls as described below:

### For radii 10m or greater

Use 9mm thick ExoTec™ facade panels which can be easily bent to the curve of the frame. ExoTec™ facade panels are to be fixed in a horizontal orientation only. Refer to Table 4 for maximum top hat spacing.

TABLE 4

MAX. TOP HAT SPACING FOR VARIOUS RADII		
RADII (m)	MAX. TOP HAT SPACING (mm)	
	900mm wide panels	1200mm wide panels
10 to 15	300	400
>15	450	To suit wind loading

## NOTES

1. The closer the spacing of top hats, the less likely they will read through as facets in the panels, particularly at a small radii.
2. 9mm thick panels may be able to be curved to a smaller radius, but this is likely to overstress panels.

## NOTE

When fixing curved sheets, commence fixing from the centre and work outwards to avoid “drumminess”.

Particular care should be taken when curving panels to ensure the supports are on a true curve. If not, apart from poor appearance, there is a risk of locally over-stressing the panels and causing cracking.

Alternate materials and installation methods are available for radii less than specified above including, glass reinforced cement (GRC) installed according to manufacturer’s specifications.

For further information on curved facades contact James Hardie on 13 11 03.

Movement joints are required to limit or remove stresses from the panels. Movement joints are provided by the nominal 10mm expressed or sealant filled joints at the perimeter of the panels.

Vertical structural joints may be required in the cladding to coincide with structural joints in the structure to accommodate the anticipated movement.

Horizontal structural joints are required at slab level where the framing supporting the top hats moves with the creep deflection in the slab.

For details of abutment to masonry walls, refer page 7 in the ExoTec™ Facade Panel and Fixing System Technical Specification.

For more information on movement joints, refer page 6 in the ExoTec™ Facade Panel and Fixing System Technical Specification.

## NOTE

The project engineer is responsible for specifying the anticipated movement.

# 9 JUNCTIONS

## BASE SLAB JUNCTION

This junction can be treated in a number of ways, two of which are illustrated in Figures 23 and 25.

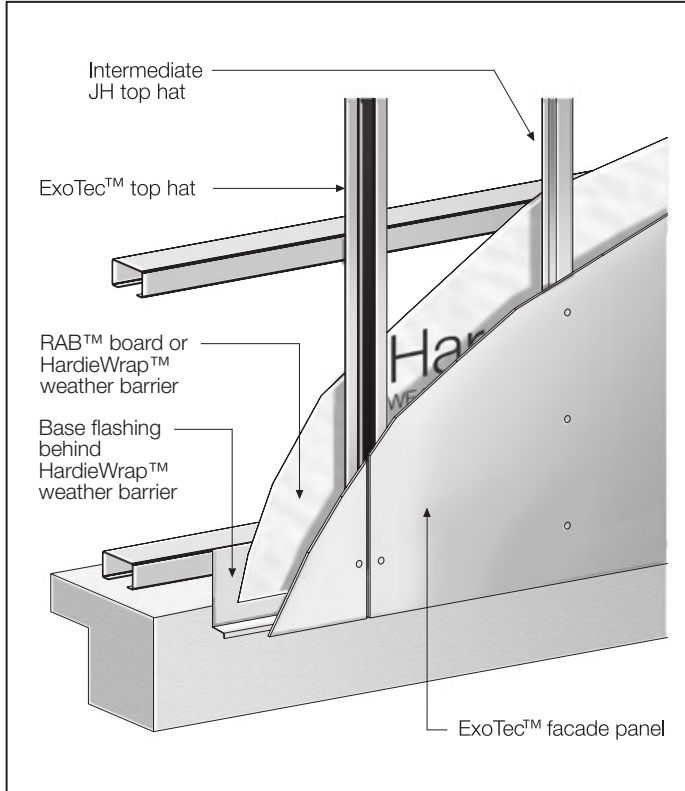


FIGURE 23 WALL BASE TYPICAL CUTAWAY DETAIL 1

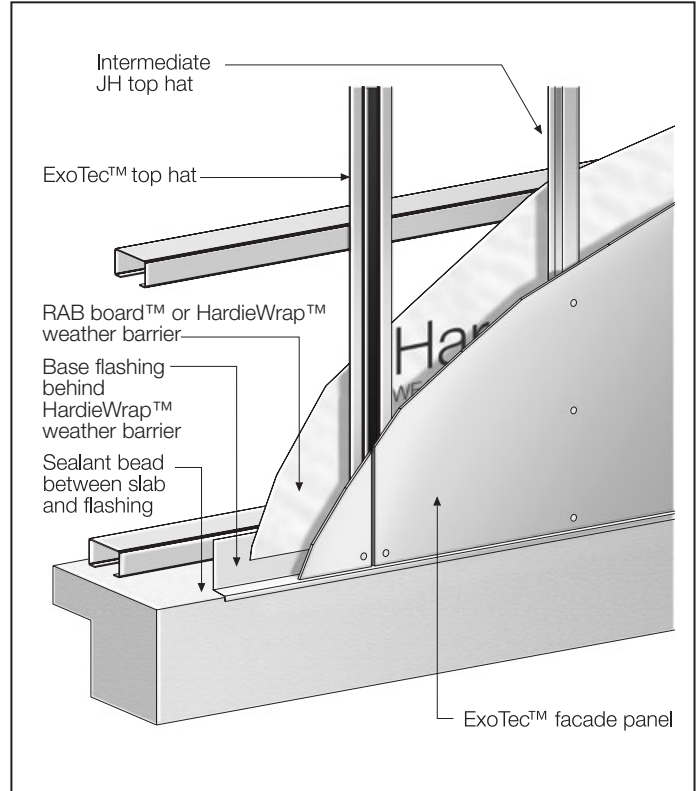


FIGURE 25 WALL BASE CUTAWAY TYPICAL DETAIL 2

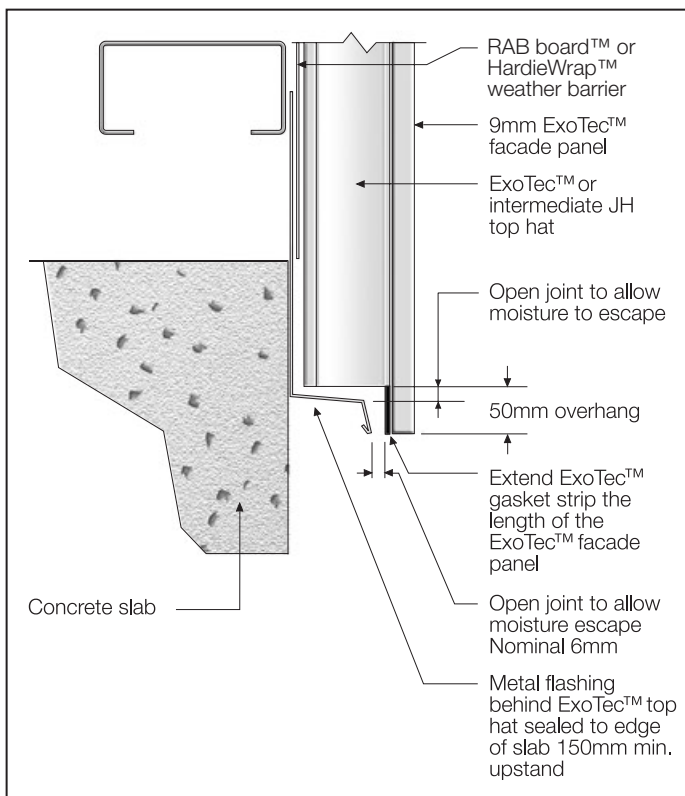


FIGURE 24 WALL BASE TYPICAL DETAIL 1

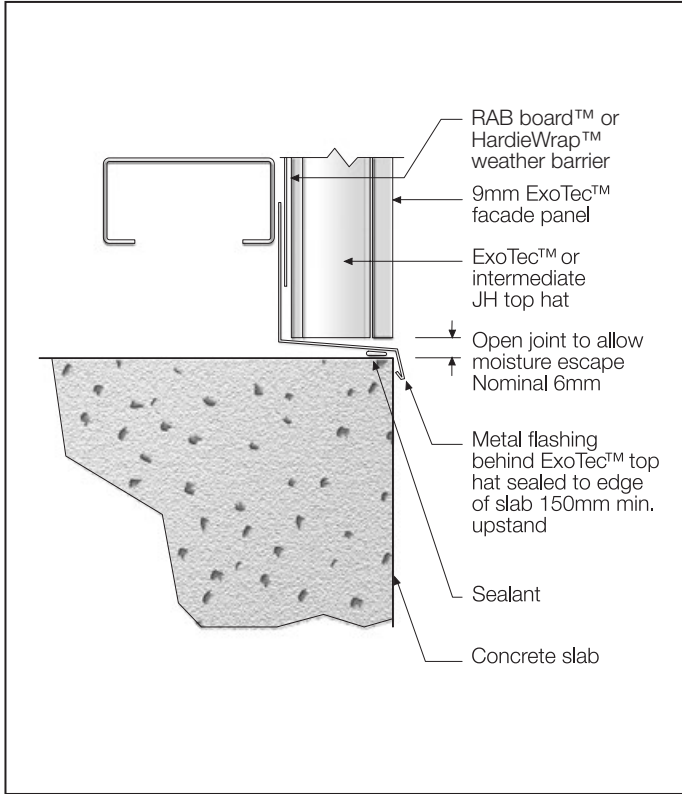


FIGURE 26A WALL BASE TYPICAL DETAIL 2

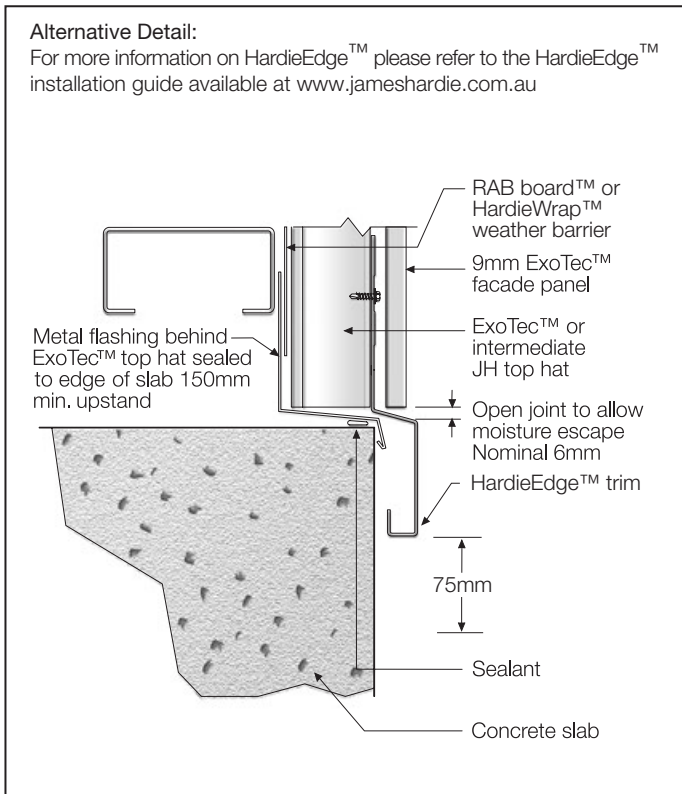


FIGURE 26B WALL BASE TYPICAL DETAIL 2 WITH HARDIEEDGE™ TRIM

## HEAD SLAB JUNCTION

Where the cladding forms a junction with an exposed slab, the detail must accommodate for slab deflection. Refer to the structural engineer for appropriate recommendations. A typical deflection head detail is shown in Figure 27.

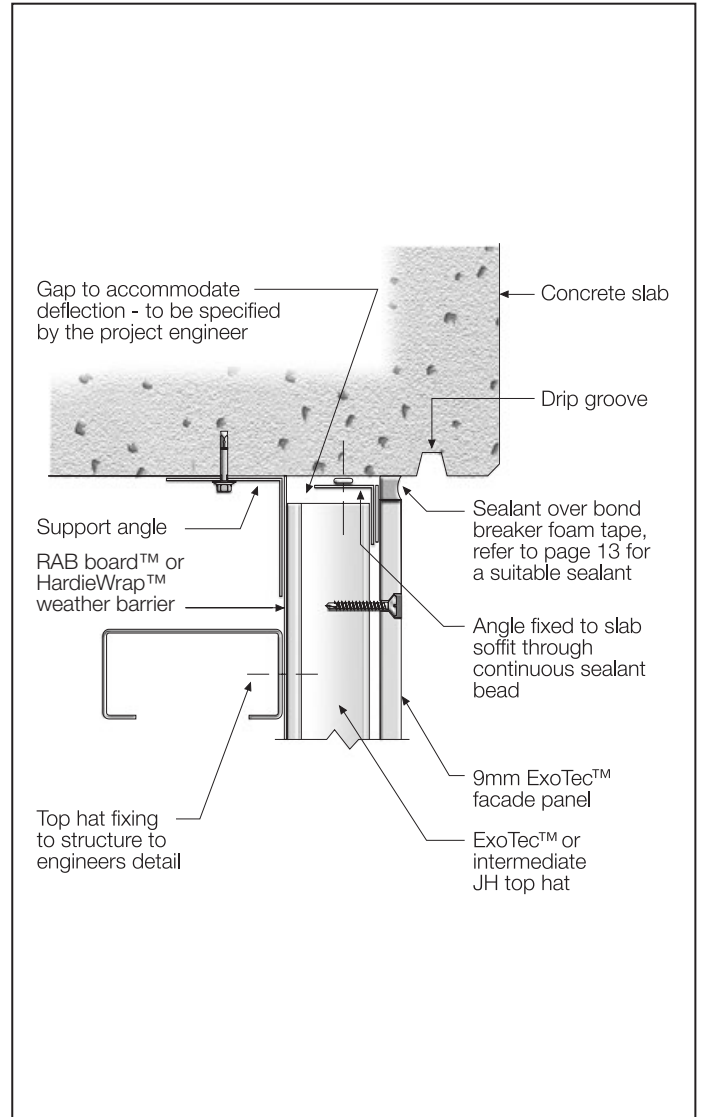


FIGURE 27 WALL DEFLECTION HEAD USED UNDER SLAB

# 10 EXTERNAL CORNERS

## SOFFIT JUNCTION

There are many ways of detailing the soffit junction and it is important to ensure that a drip edge is provided. A typical approach to install the soffit fascia junction is shown in Figure 28. Ensure the ExoTec™ gasket snap strip is installed to the bottom of the fascia panel.

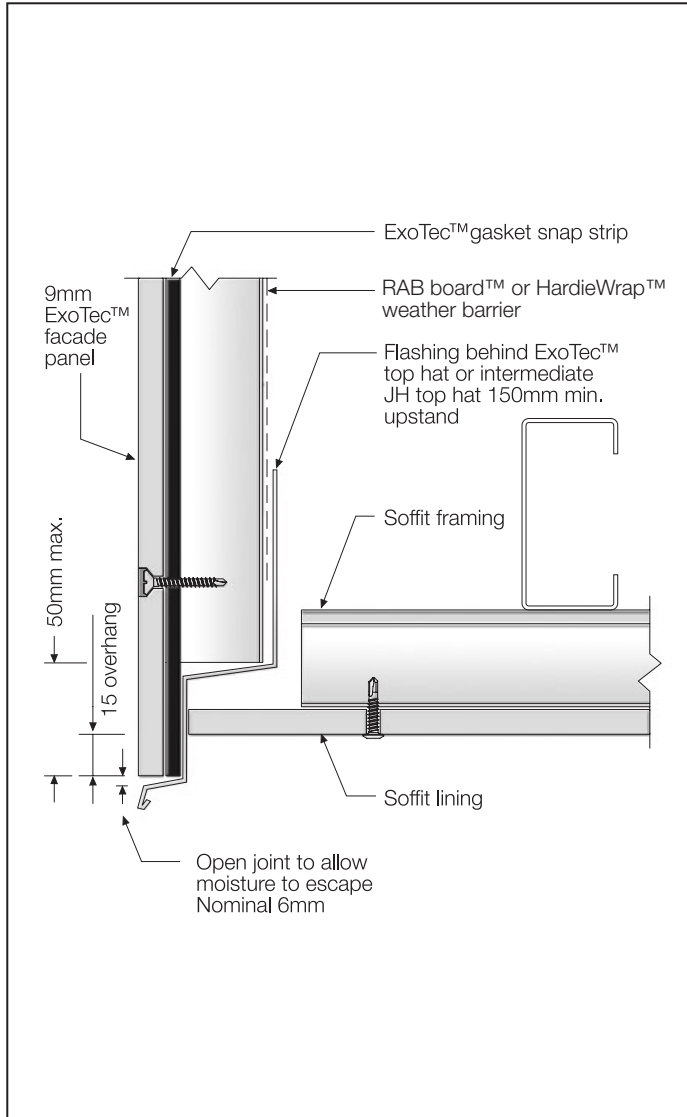


FIGURE 28 TYPICAL SOFFIT DETAIL

### NOTE

It is essential that a continuous flashing is provided behind the top hats at the base of the fascia to allow moisture to escape. See Table 5 of the ExoTec™ Facade Panel and Fixing System Technical Specification for required height of the flashing upstand.

This section contains various methods of finishing external corners using the ExoTec™ facade panel and fixing system

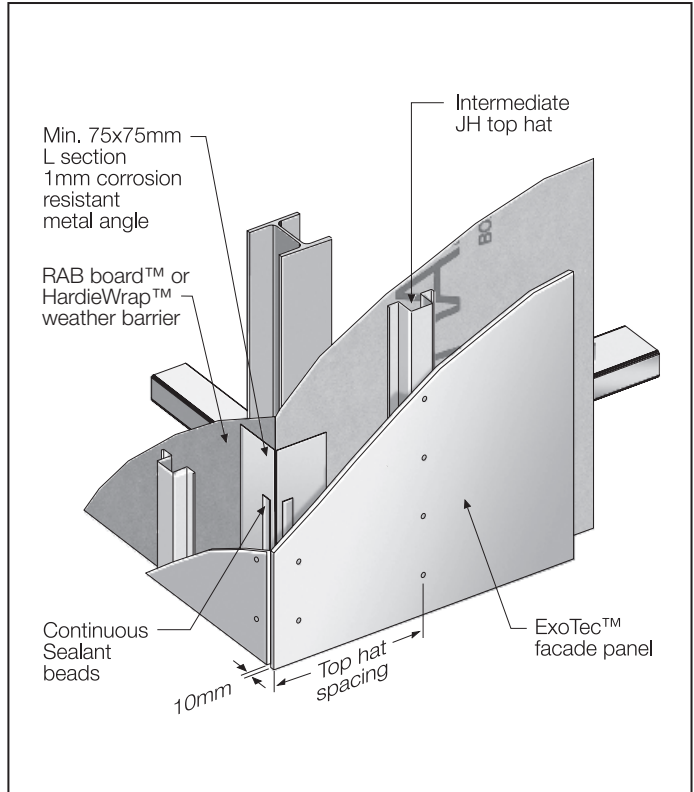


FIGURE 29 EXTERNAL CORNER CUTAWAY DETAIL

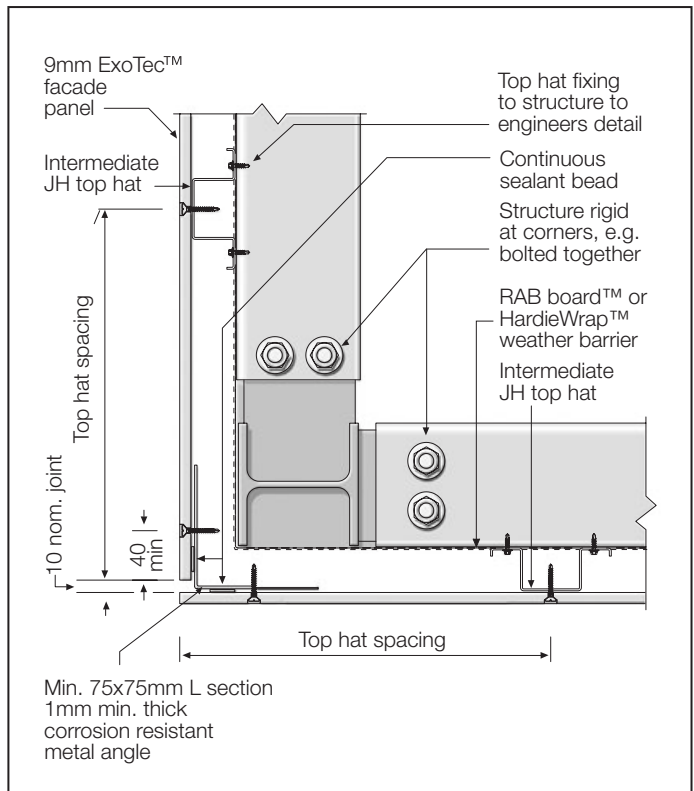


FIGURE 30 EXTERNAL CORNER DETAIL



# 11 INTERNAL CORNERS

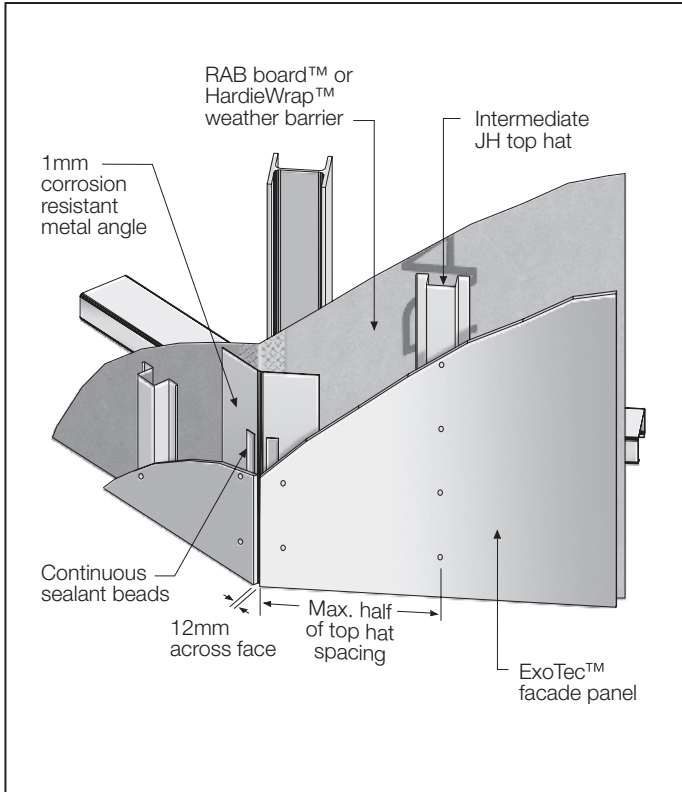


FIGURE 31 NON SQUARE EXTERNAL CUTAWAY CORNER

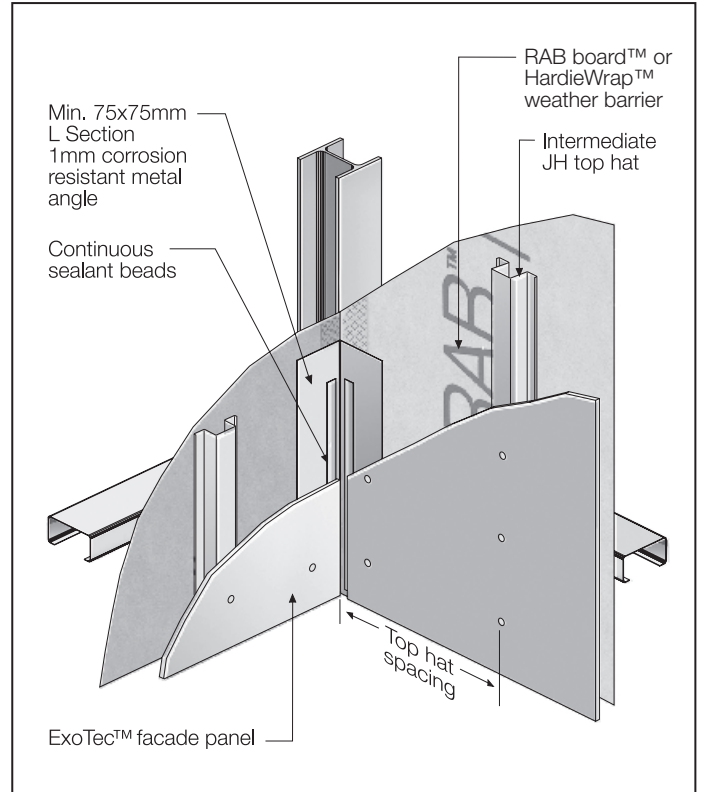


FIGURE 33 INTERNAL CORNER CUTAWAY DETAIL

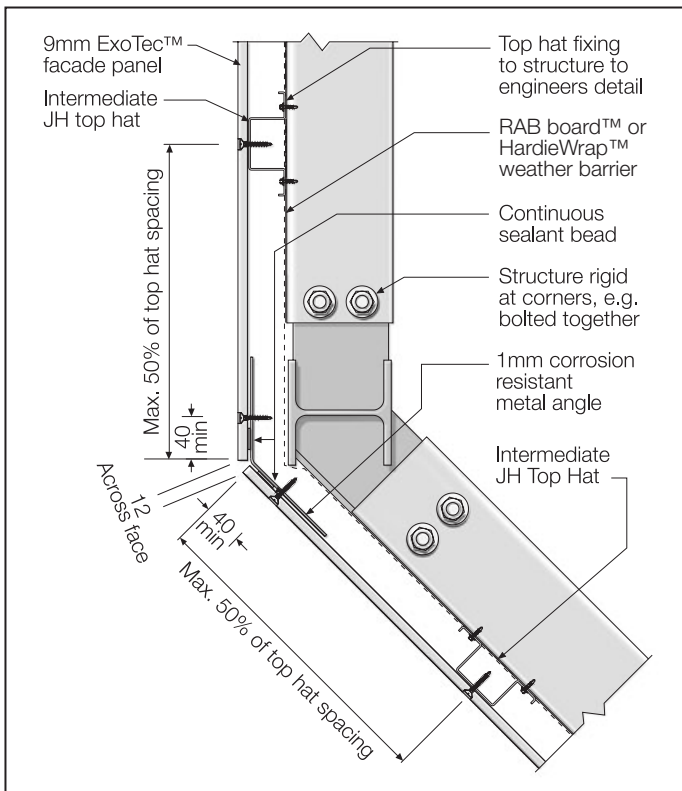


FIGURE 32 NON SQUARE EXTERNAL CORNER

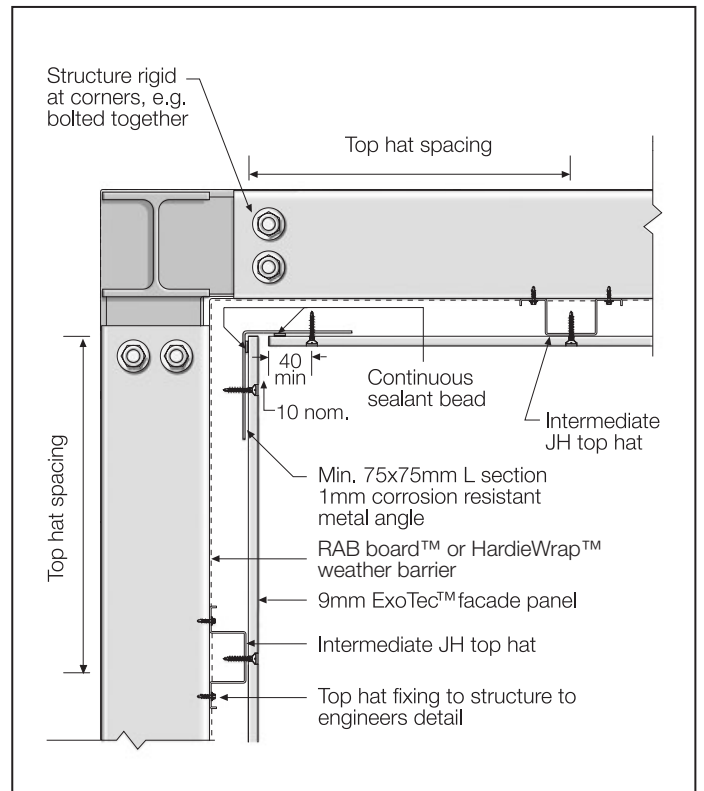


FIGURE 34 INTERNAL CORNER DETAIL

# 12 WINDOWS

The ExoTec™ facade panel and fixing system provides an opportunity to consider a range of alternative window treatments. The building designer, in conjunction with the window manufacturer, must consider the adequate weatherproofing of the window application.

Windows may be flush with the facade using figures 35– 45. This is a guide only. All windows are different and sufficient provision for moisture management must be made, see Clause 2.5 of the ExoTec™ Facade Panel and Fixing System Technical Specification.

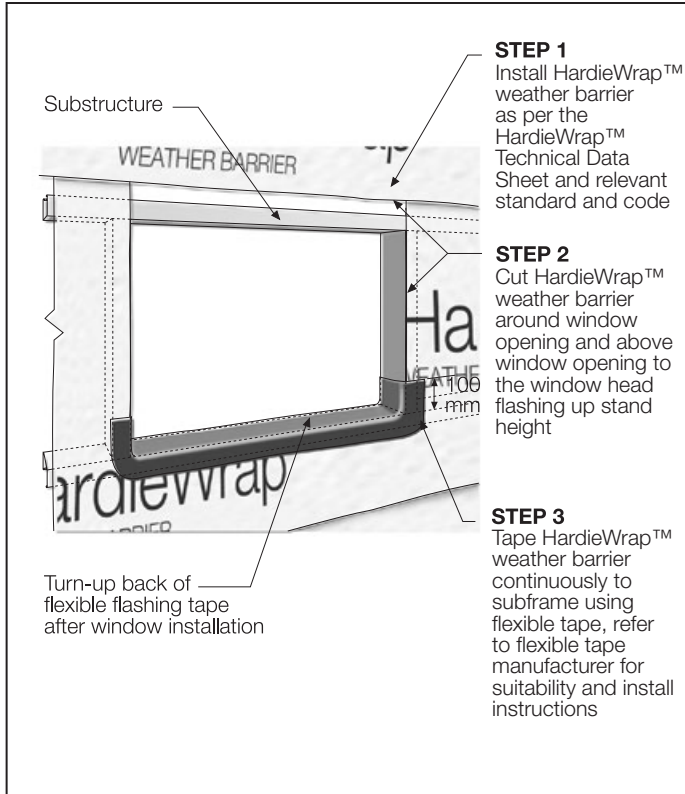


FIGURE 35 INSTALLATION OF HARDIEWRAP™ WEATHER BARRIER

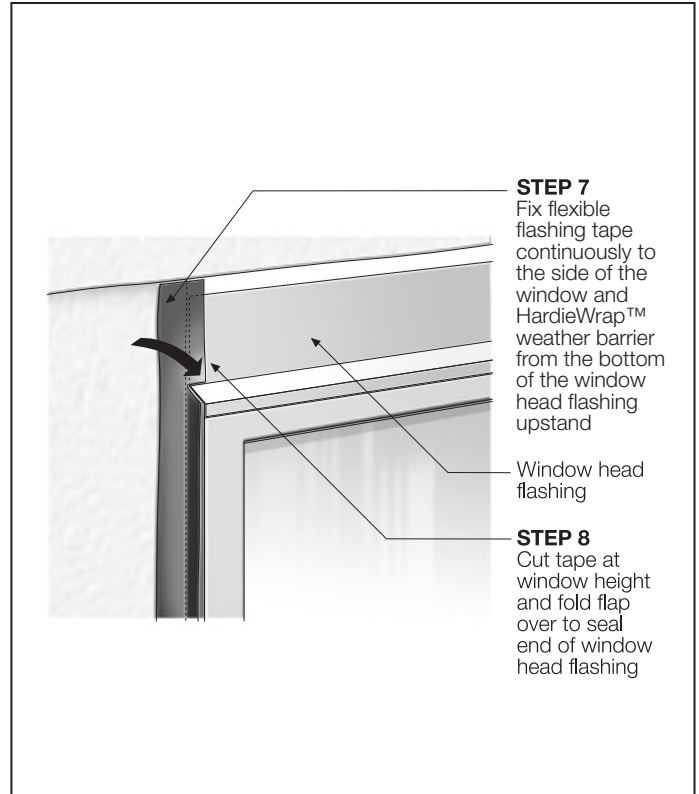


FIGURE 37 HEAD INSTALLATION OF WINDOW

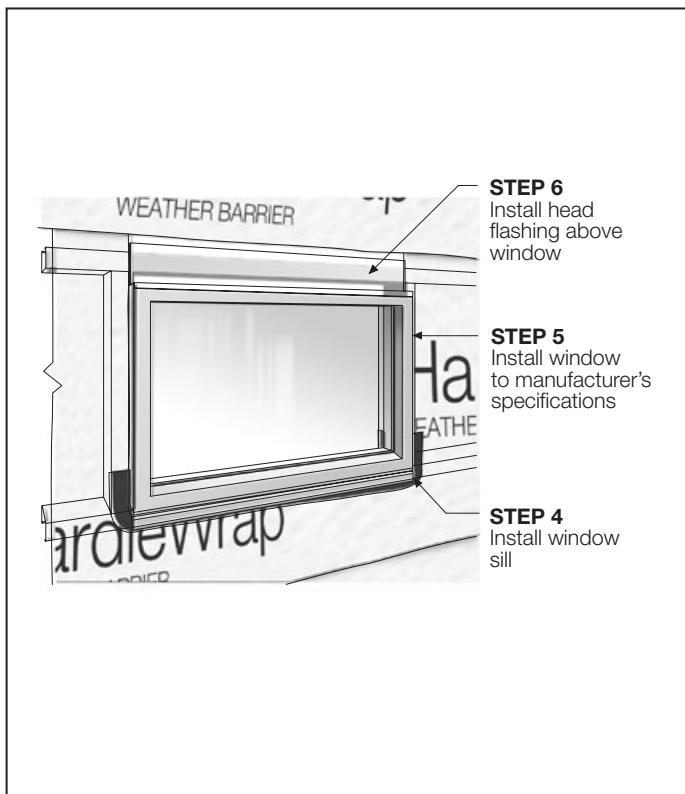


FIGURE 36 INSTALLATION OF WINDOW



FIGURE 38 INSTALLATION OF WINDOW

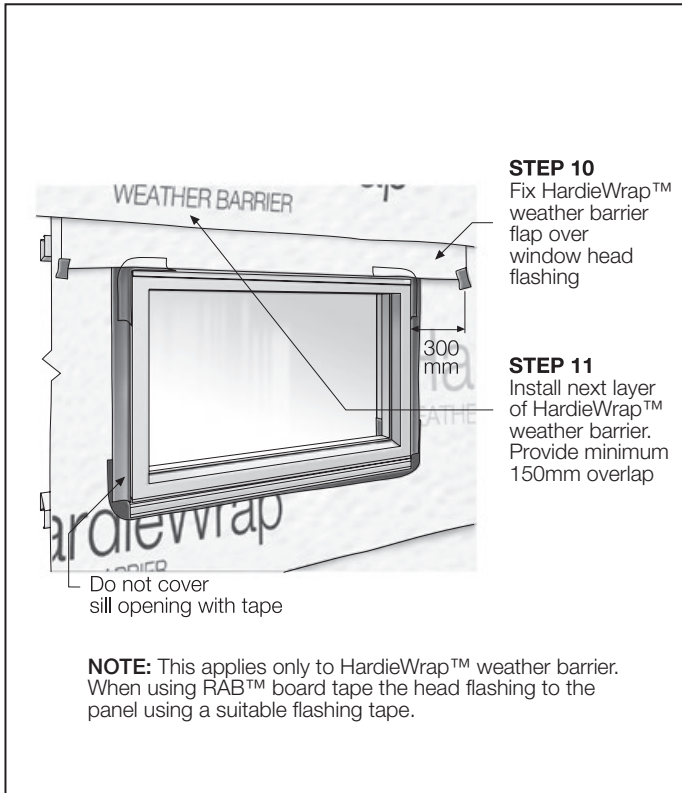


FIGURE 39 PREPARATION AROUND WINDOW

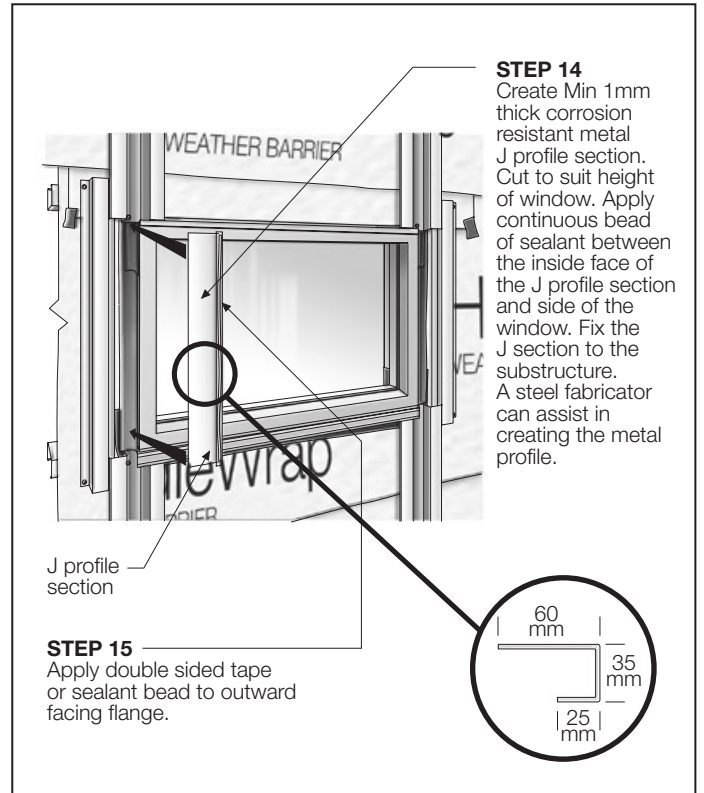


FIGURE 41 INSTALLATION OF J SECTION

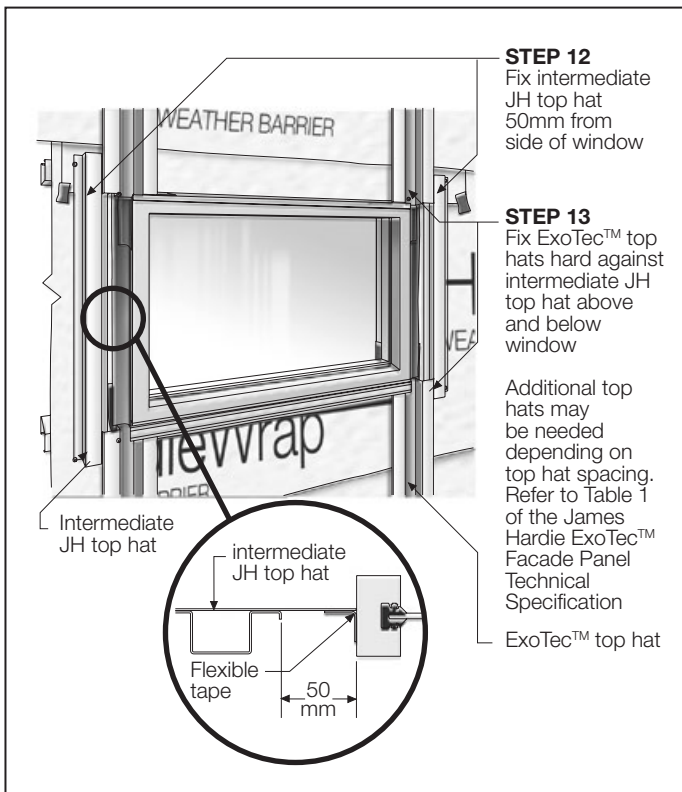


FIGURE 40 INSTALLATION OF TOP HATS AROUND WINDOW

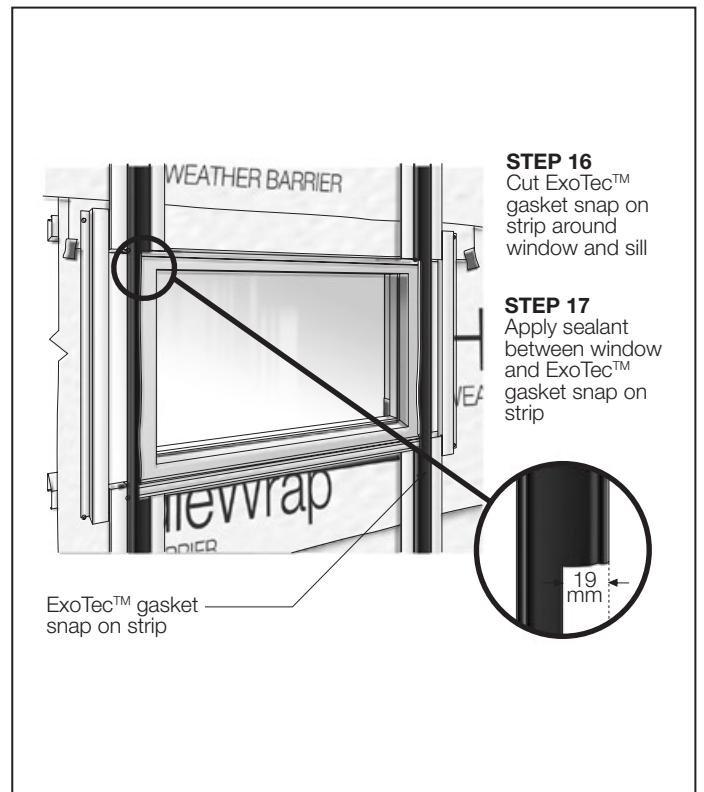


FIGURE 42 INSTALLATION OF SNAP ON STRIP

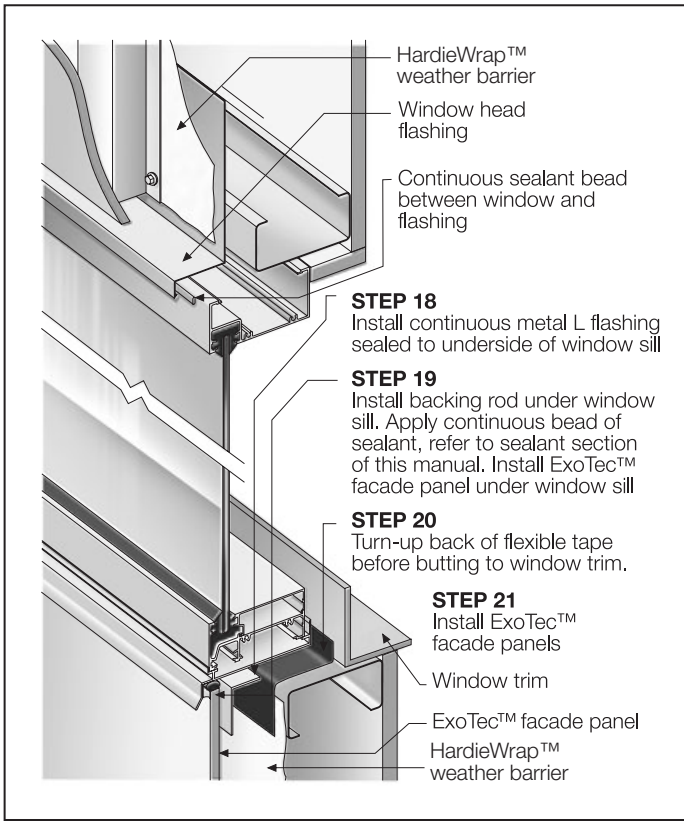


FIGURE 43 OVERVIEW CUTAWAY SECTION OF WINDOW

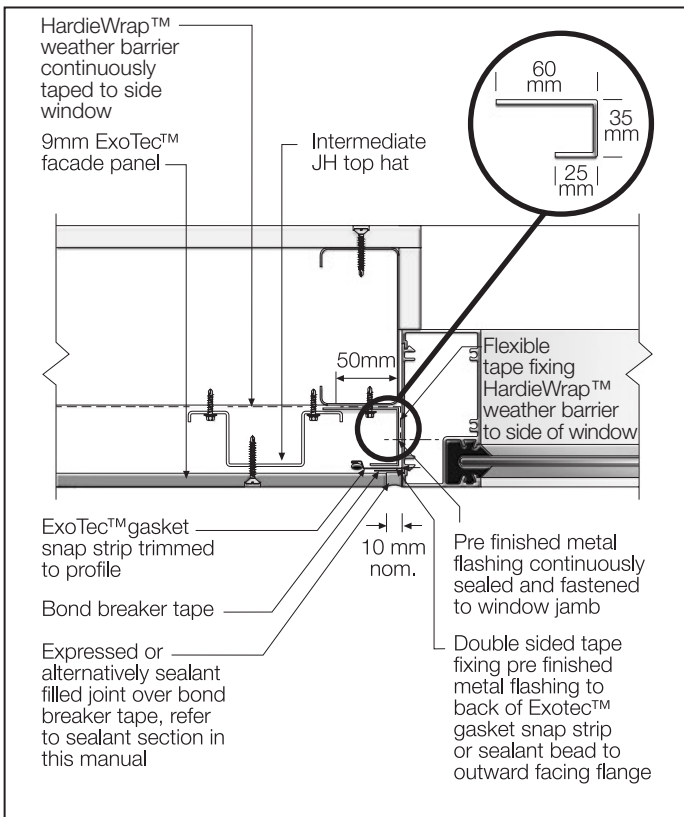


FIGURE 44 WINDOW JAMB DETAIL

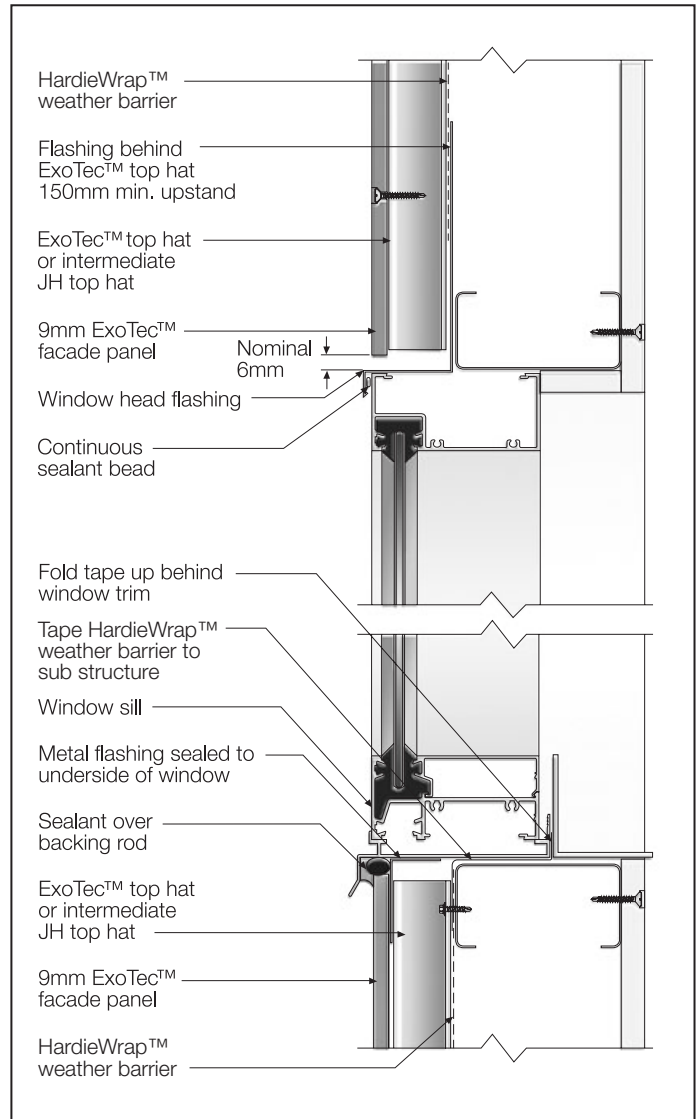


FIGURE 45 CROSS SECTION OF WINDOW



# 13 PARAPET DETAILS

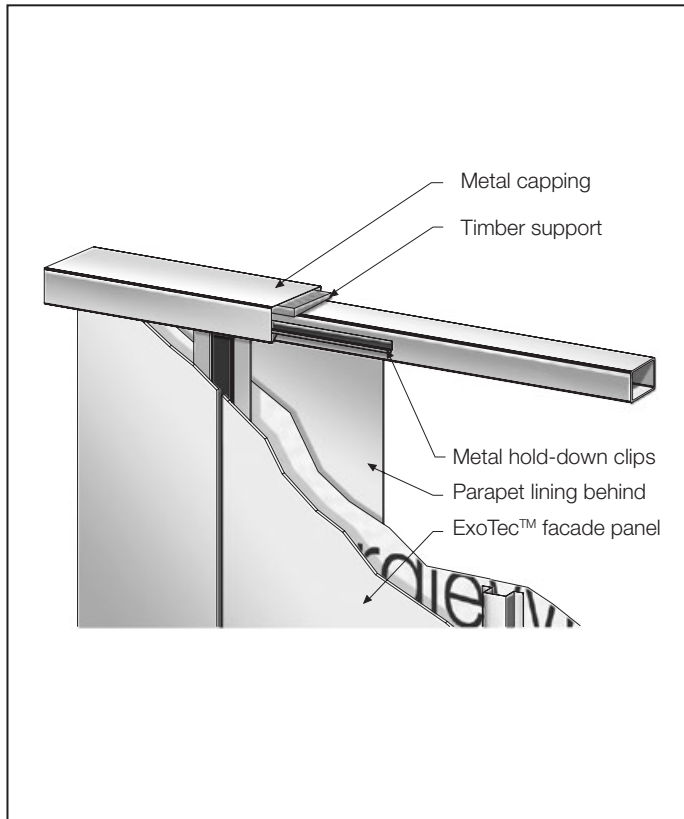


FIGURE 46 PARAPET CAPPING CUTAWAY DETAIL 1

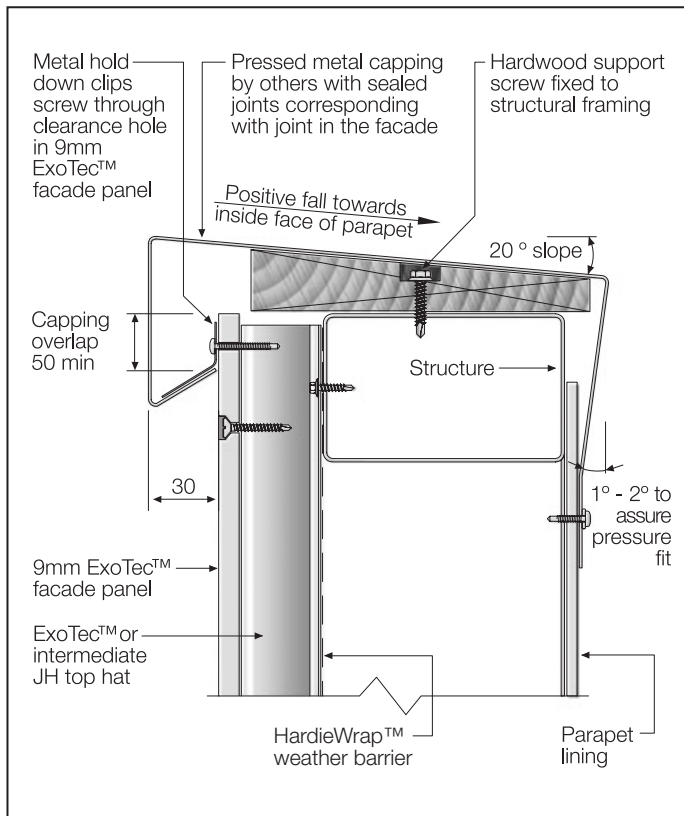


FIGURE 47 PARAPET CAPPING DETAIL 1

# 14 FINISHING

## GENERAL

### Painted ExoTec™ Facade Panels

ExoTec™ facade panels will readily accept a wide variety of applied finishes, including site-applied textures and factory finishes. For site-applied finishes (acrylic coatings), follow the paint manufacturer's recommended advice to adequately cover the sanded smooth James Hardie™ base coat filler applied over the epoxy filled concealed fixings (refer to fixing section).

In order to seal cut edges or sanded patches two coats of an appropriate primer should be applied at the time of cutting or sanding e.g. Dulux AcraPrime 501/1 (water based).

The face and edges of the panels must be coated in accordance with the paint manufacturer's recommendations.

For further information contact the service centre of the relevant paint company, as follows:

- Dulux Trade Customer Service on 13 23 77
- Taubmans Customer Service on 13 16 86
- Wattyl Hotline on 13 21 01

### ExoTec™ Vero™ Facade Panels

Site cut edges or sanded patches must be resealed using Vero™ Edge Sealer.

It is best practice to install resealed site cut edges on a horizontal edge at the bottom of the sheet, or on a vertical edge that is not directly exposed. Any surface marks/dirt should be washed off with clean water and a clean rag/brush. Do not use detergent or solvents to clean any surface marks. Any surface scratches must also be resealed.

Apply two coats of sealer generously to site cut edges using a clean brush, roller or sponge. Refer to Vero™ Edge Sealer box and bottle for more information.

### Pre-finished (3rd Party) ExoTec™ Facade Panels

Polyurethane paints are not suitable as a site-applied finish but can be factory coated prior to installation. Pre-finished panels are generally installed using colour-matched exposed head fasteners.

Some environments require special coatings. Painting selection and specifications are dependant on the paint chosen. Refer to the paint manufacturer.

Fixing tiles onto ExoTec™ facade panels is not recommended.

## PANELS EXPOSED TO DIRECT SUNLIGHT

The Exotec™ panels, except for Exotec™ Vero™, must not be exposed to direct sunlight for any period greater than three months. The face must be over-coated as recommended by the paint companies mentioned above. However, if the rear clear sealer is exposed to direct sunlight by its application, e.g. fascias, plantrooms, etc., then the clear sealer must be coated with a minimum of two coats of an exterior grade acrylic, pigmented white, with a minimum of 10 years warranty, by one of the paint companies previously mentioned.

**It is the responsibility of the specifier to identify other weather related risks with any particular building design.**

### NOTE

Refer to the previously mentioned paint companies for suitable rear face surface preparation on the ExoTec™ facade panels.

# 15 MAINTENANCE

## COASTAL AND ALPINE AREAS

In coastal areas located within 1km\* of the shoreline or large expanses of salt water (e.g. Port Phillip Bay, Sydney Harbour east of the Spit and Harbour Bridges, Swan River west of the Narrows Bridge), one of the following is required:

- All horizontal and vertical expressed joints must be filled with a suitable sealant, refer to the sealant filled joints section within this specification.
- Where both the horizontal and vertical expressed joints are not filled, the joints and panels must be washed down twice a year. On unprotected walls, rain will perform this washdown, but where walls are protected by soffits above, the washdown twice per year is a maintenance requirement.

ExoTec™ Vero™ panels must not be used within 50m of an oceanfront or in areas subject to freeze thaw conditions, such as alpine areas.

It is the responsibility of the specifier to determine normal maintenance requirements.

The extent and nature of maintenance will depend on the geographical location and exposure of the building. As a guide, it is recommended that basic normal maintenance tasks shall include but not be limited to:

- In coastal areas, a six monthly washdown of expressed joints must be done.
- Annual checks and maintenance for the exposed sealant (3mm fillet at horizontal joints, filled vertical and horizontal joints) referenced in Clauses 6.2, 6.3, 6.4, 6.5, 6.6, 7.1, 9, 11.1 and 11.2, must be done as required by the sealant manufacturer, refer to the current ExoTec™ Facade Panel and Fixing System Technical Specification.
- Maintenance to painted surfaces must be carried in accordance with the paint manufacturer's specification, refer to section 14 in this manual.
- As required, clear debris build up against ExoTec™ facade panels.
- Maintain sealant as per manufacturer recommendations, to ensure weather seal.
- Clean out gutters, blocked pipes and overflows as required.

To retain the durability and water-resistant properties of ExoTec™ Vero™ facade panels, James Hardie recommends recoating panels with a clear penetrating sealer every 10 years.

More frequent re-sealing may be required for panels installed in harsher environments, for example, coastal areas, exposure to chemicals or pollutants.

# NOTES



**For information and advice  
call 13 11 03 | [jameshardie.com.au](http://jameshardie.com.au)**

**Australia** November 2019

© 2019 James Hardie Australia Pty Ltd ABN 12 084 635 558  
™ and © denote a trademark or registered mark owned by James Hardie Technology Limited.

