

CHAIN™ COLLATED CLIP USERS GUIDE



chain™
Collated decking clip

SCOPE

Introduction

Thank you for choosing CHAIN™ Collated decking clip. This guide aims to provide the essential information needed to successfully install the CHAIN™ Collated decking clip products. It is assumed that the user of this document has a basic understanding of deck building practices and pertinent building codes.

All work must comply with the applicable standards and codes for the region and the user should ensure compliance with material manufacturer specifications. Where manufacturer and building codes differ, revert to the building code requirements. An appropriately qualified professional must be consulted whenever necessary to ensure the product, this document and the intended application comply with all applicable legislation for the region.

Product lifespan

The durability of a system is dependent on the application and environment in which it is installed. The installation should attempt to match the weatherability of all components of the deck system (substructure, fasteners, and boards). A component that is considerably less durable than the system will dictate the overall performance of the system. Consult a suitably qualified professional when necessary to ensure adequate lifespans will be achieved for the intended application. Refer to the appropriate warranty document(s) where necessary.

Maintenance requirements

Continuous maintenance will ensure that the system achieves anticipated lifespans. Inspections should be conducted during installation to ensure protective coatings are not removed from the fasteners or clips. Where this has occurred, it is advisable to touch up these areas with a suitable coating. Regular inspections should also be carried out throughout the lifespan of the deck. Exposed metal surfaces or incidents of corrosion should be rectified before detrimental impact on the system occurs. Please do not hesitate to contact Eva-Last® should you require any additional assistance.

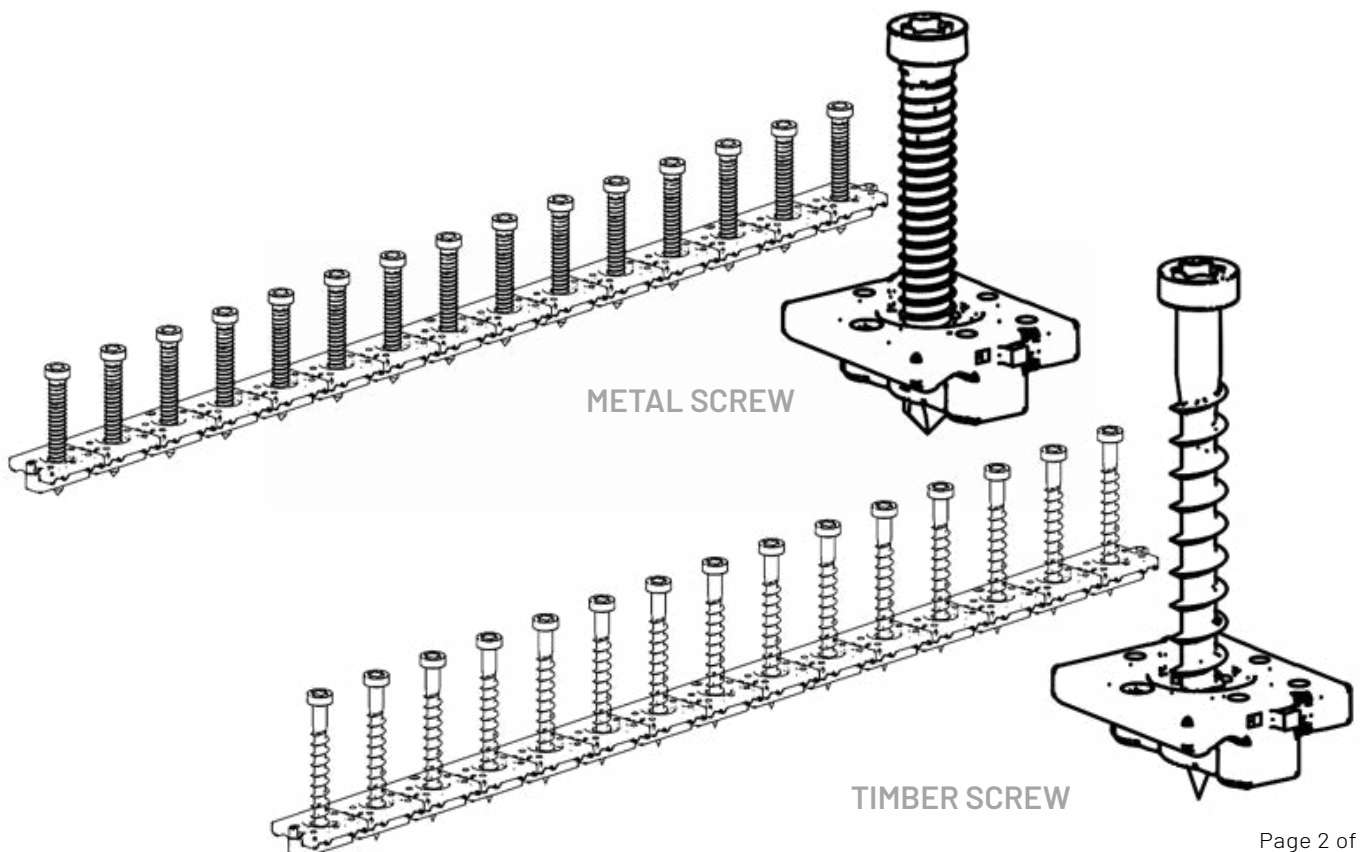

SAFETY

Refer to the applicable Material Safety Data Sheet (MSDS) for additional information.' Please do not hesitate to contact Eva-Last® should you require any additional assistance.

Always wear appropriate Personal Protective Equipment (PPE) for the various activities involved in installing a decking system. This includes, but is not limited to, equipment such as safety glasses, helmets (where necessary), gloves and boots, dust masks when cutting or similar, and harness systems when working at heights or similar, as dictated by the local occupational health and safety legislation.

Be mindful of the following:

- Cutting deck boards produces fine particulate matter which is harmful if inhaled.
- Work in well-ventilated areas.
- Wear dust masks during cutting, drilling, and cleaning.
- Clean up particulate matter by vacuuming or wetting down the area and sweeping regularly. Alternatively, capture particulate matter using a drop sheet where possible.
- Always wear safety goggles while cutting and during installation.
- Cut boards may have sharp edges (particularly mitred cuts).

STORAGE AND HANDLING



- Wear safety gloves when handling individual unpackaged strips.
- Keep collated strips relatively straight during installation.
- Support the first clip during installation and avoid unnecessary load distribution to subsequent clips or collation tabs.
- Improper handling may result in collations separating before use.
- All components should be stored under cover.
- When storing boxes, a pallet or flat surface should be used to support the box.
- All components should be securely stored.
- No component should sit in water, other liquids, or contaminants.
- Avoid eccentric stacking or over-stacking.

STANDARDS

Legislation may differ between jurisdictions. Before installing any Eva-Last® product, ensure that the application is appropriate and complies with local regulations and building codes. Wherever necessary, consult a suitably qualified professional. Be sure to comply with material manufacturer specifications. Where manufacturers and building codes differ, revert to the building code requirements. Check that your choice of product is suitable for its intended application. For further product specification and information visit www.eva-last.com.

CLIP STRIP OVERVIEW

A single Chain™ collated decking clip strip consists of a magazine of 15 clips with pre-loaded screws. Screws are available for both timber, and similar, as well as metal substructure substrates. Each clip consists of a stainless-steel skeleton wrapped in a polymer coating, this polymer also forms the base and collation for the clips.

Description	Number of clips and screws	Screw type	Application
Timber application collated clip	A strip of 15 clips with 15 screws.	 Timber clip screw. M4.2 x 40 mm. Stainless Steel 316, epoxy coated.	Designed for timber and composite substructure.
Metal application collated clip	A strip of 15 clips with 15 screws.	 Metal clip screw. M4.2 x 31 mm. Carbon C1022, zinc epoxy coated.	Designed for steel and aluminium substructure.

APPLICATION

Used as a hidden fastener between timber and composite grooved boards.

- Compatible with deck board grooves as detailed below.



- Typical resultant gap between boards as detailed below.

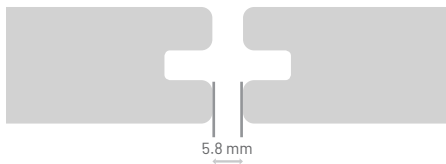

- Compatible with timber or composite joists of a minimum profile height of 38 mm and width of 38 mm.
- Compatible with metal joists of a minimum profile height of 32 mm and width of 25 mm.
- Use an electric drill with adjustable torque settings. Do not set the torque to greater than 30% of the maximum allowable. Do not use an impact driver.
- Use the collared Torx 15 bit provided in every hand-tool box and sold separately.

INSTALLATION PROCESS

Setting hand tool depth to board height

- Set the height of the hand tool relative to the board groove by adding or removing depth adjustment plates to the base of the hand tool.
- Insert the tool into the groove of the board to ensure that the plates are set to the appropriate height.

Note: Should the height be incorrectly set, the clip may not adequately grip the board, or the insertion of the following board may be negatively impacted.

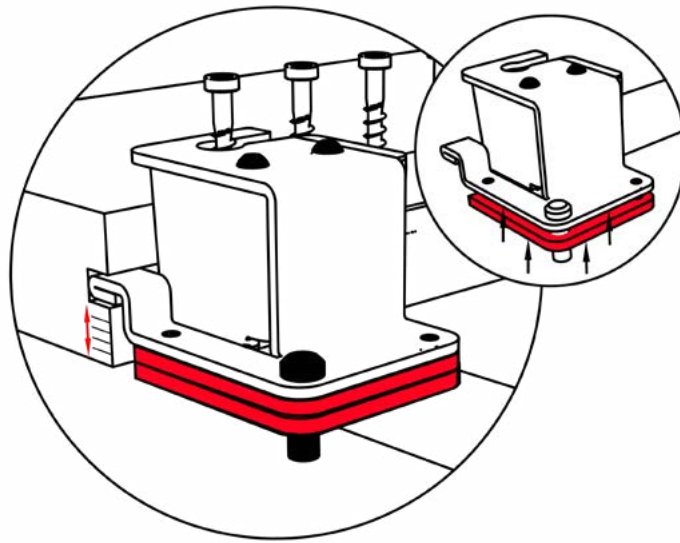

Inserting clips into a hand tool

- To load a magazine, slide the collation strip into the hand tool via the guide, and then slide the strip to the end of the tool.

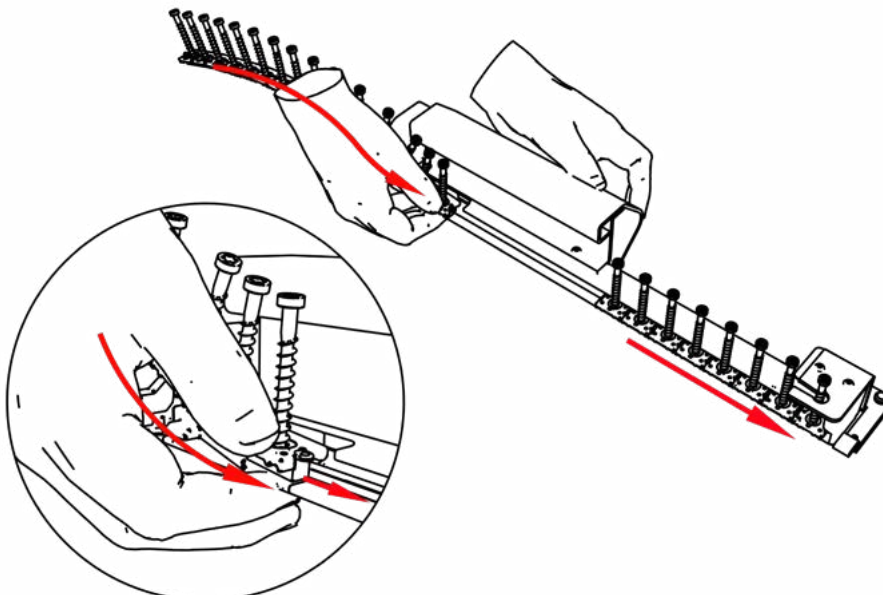

Installation of a clip

- Place the hand tool over the joist so that the base rests on the top surface of the joist. Slide the tool back towards the joist until the pivot screw rests firmly against the outer joist face. Finally, push the tool towards the board so that the tool guide slides into the board groove.

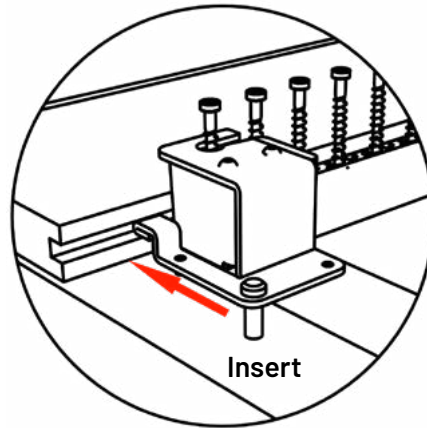

- Fasten the clip into place by installing the screw until it is fully seated on the clip. Ensure the head of the screw clears the tool and the board. Use appropriate torque and depth control.

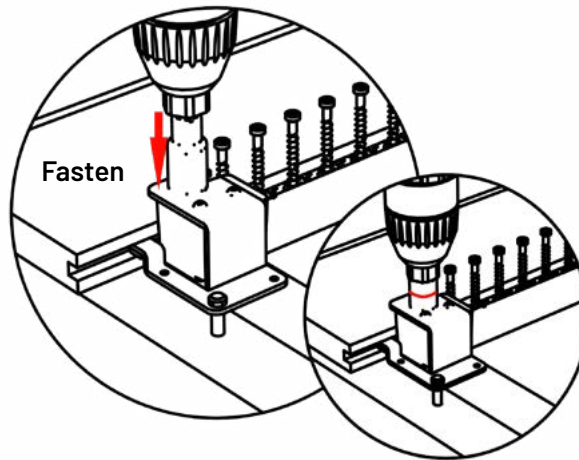

- Rotate the tool away from the board using the screw located against the joist as the pivot point. The action will tear the installed clip from the remaining collation. Slide the collation down the tool so the next clip is ready to install, and repeat.

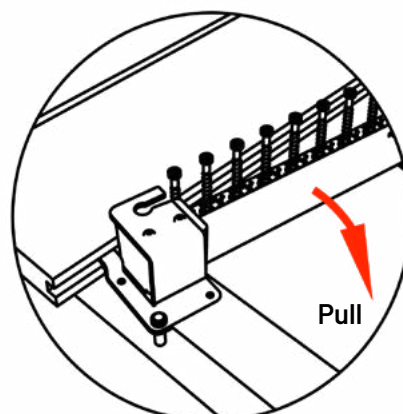

Inserting the next board

- Once a full row of clips has been fixed, the next board can be installed.
- Place the board onto the joist and leverage it under the spring of the first clip, this may require the use of a mallet or similar. Ensure the board is correctly positioned and immediately fix a new clip in place

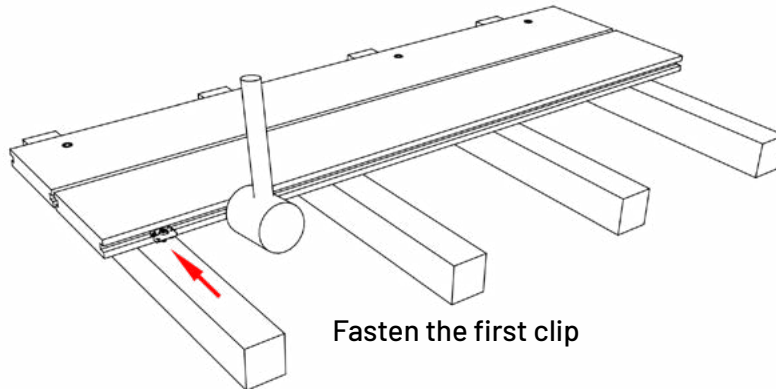

Fasten the first clip

- Move to the opposite end of the board, ensuring suitable engagement of the board with the previous row of clips, and fasten a clip in the final position, locking the board into place.

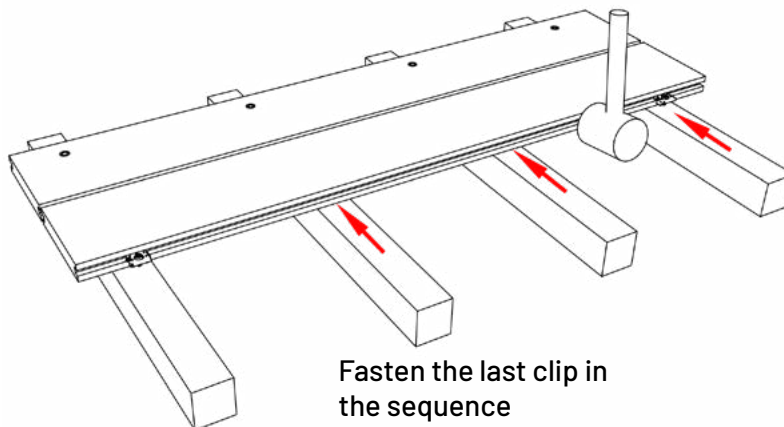

Fasten the last clip in the sequence

- Fasten the remainder of clips between the first and last clip ensuring the board is correctly positioned relative to the previous row clips.

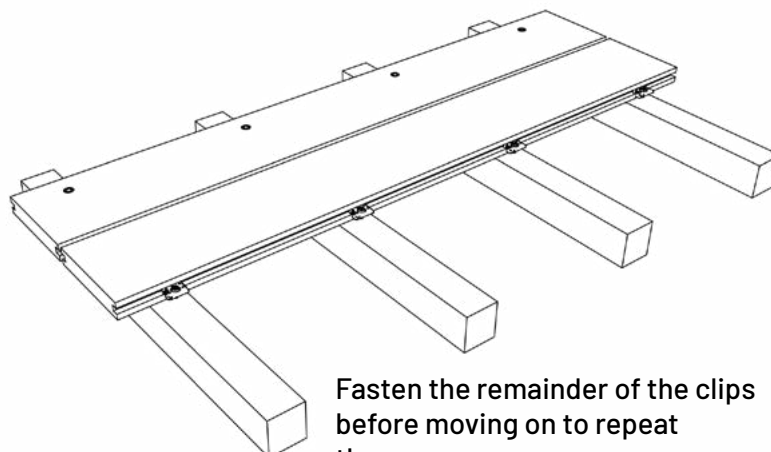

Fasten the remainder of the clips before moving on to repeat the process.

Note: It is essential not to over-tighten any fixing before the next board has been clipped in and secured. Previously installed clips can be tightened, but it is important to do this after the next row of clips has been installed to prevent the recently clipped in board from being pushed out of place.

Using Chain™ collated decking clip without a hand tool

- Ensure that the clip rests firmly in the grooves of both the board to be installed and an offcut of the same board type.
- Support the clip spring as the clip is fastened into place and do not over-tighten.
- Remove the offcut and tear the remaining collation strip away from the newly fastened clip.

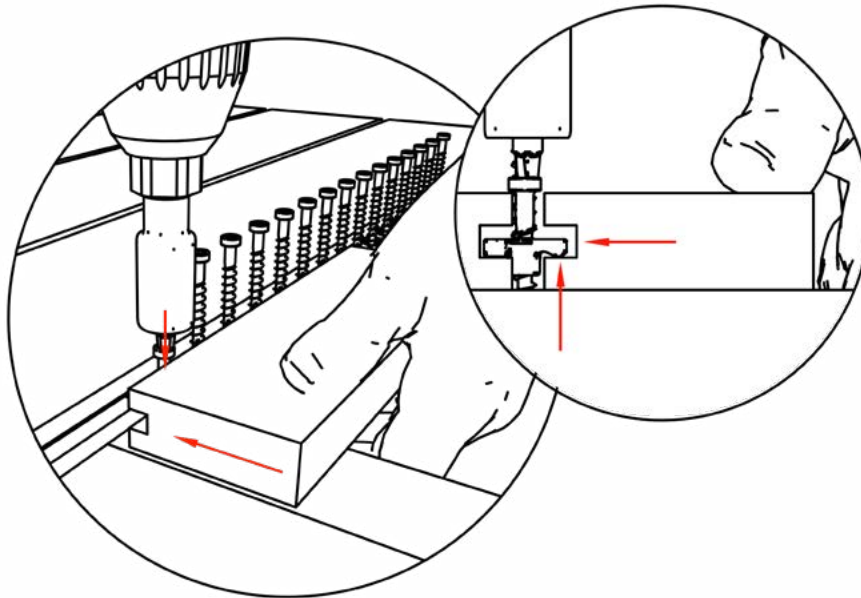

DISCLAIMERS AND COPYRIGHT

Document disclaimer

The provided information is offered in good faith as accurate but without guarantee. Eva-Last® makes no warranties or representations of any kind (express or implied) about the accuracy, adequacy, currency, or completeness of the information, or that it is necessarily suitable for the intended use. Compliance with this document does not guarantee immunity from breach of any statutory requirements, building codes or relevant standards. The final responsibility for the correct design and specification rests with the designer and, for its satisfactory execution, with the contractor. Appropriate warnings and safe handling procedures should be provided to handlers and users.

While most data have been compiled from research, case histories, experience and testing, small changes in the environment can produce marked differences in performance. The decision to use a material, and in what manner, is made at your own risk. The use of a material and method may therefore need to be modified to its intended end use and environment.

Eva-Last®, its directors, officers or employees shall not be responsible for any direct, indirect, or special loss or damage arising from, or as a consequence of, use of, or reliance upon, any information contained in this document or other documents referenced herein. Eva-Last® expressly disclaims any liability which is based on or arises out of, the information or any errors, omissions, or misstatements herein

Utilisation disclaimer

Legislation may differ between jurisdictions. Before installing any Eva-Last® product, ensure that the application is rational and complies with the local regulations and building codes. Wherever necessary, consult a suitably qualified professional. Be sure to comply with material manufacturer specifications. Where manufacturers and building codes differ, revert to the building code requirements. Check that your choice of product is suitable for its intended application. For further product specification and information visit www.eva-last.com.

Copyright

If reprinted or reproduced or utilised in any form Eva-Last® should be acknowledged as the source of the information.

Eva-Last® periodically updates the information contained in this document as well as that of the Eva Last® documents that have been referenced herein. Before using this document, please refer to the Eva-Last® website (www.eva-last.com) for the most up-to-date documents. Please also refer to the applicable websites.

APPENDIX

Appendix A: Coverage

Coverage is defined as the average number of clips required to install a square metre of decking based on the width of the board and the joist span used. The total number of clips required for a project is calculated by multiplying the applicable coverage rate with the total expected area of the deck. A wastage factor is typically allowed for and depends on the complexity of the project. A common industry assumption for a standard install is a wastage of approximately 10%.

Clips per square meter (m²)

Board width (mm)	Deck span (mm)					
	300	350	400	450	500	600
135	26	23	20	18	16	14
140	25	22	19	17	16	13
145	24	21	19	17	15	13
150	24	21	18	16	15	13
180	20	17	15	14	13	11

Note: Board width includes an average gap of 6 mm between subsequent boards. Wastage is not considered in the above table.

Appendix B: Fastener specification

Timber

Chain™ Collated deck clip timber screws are used for both timber and composite substructure substrates. Available in 316 stainless steels with an epoxy coating.

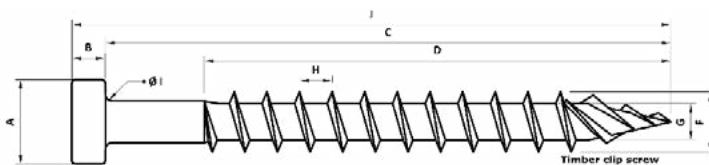

Item	Description	Dimension (mm)
A	Head diameter	6.0
B	Head height	2.3
C	Useable screw length	38 to 40
D	Thread length	30 to 33
E	Tip length	N/A
F	Major diameter of screw	4.2
G	Minor diameter of screw	2.6
H	Pitch	2.3
I	Radius under head	1.0
J	Total screw length	40 - 42
	Wire gauge	2.95

Appendix B: Fastener specification

Metal

Chain™ Collated deck clip metal screws are used for metal substructure of thicknesses from 1.2 mm to 2.0 mm. Available in Carbon C1022 with a zinc-epoxy coating.

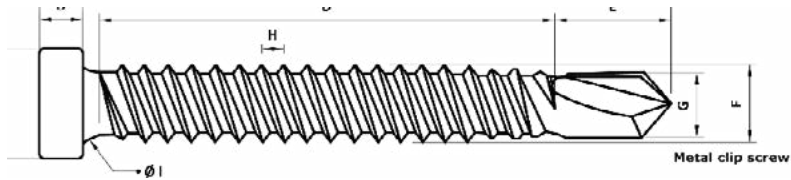

Item	Description	Dimension (mm)
A	Head diameter	6.0
B	Head height	2.3
C	Useable screw length	30 to 32
D	Thread length	30 to 32
E	Tip length	4.0
F	Major diameter of screw	4.2
G	Minor diameter of screw	3.4
H	Pitch	1.4
I	Radius under head	3.0
J	Total screw length	32 to 35
	Wire gauge	3.45