

Looking for the  
**EasyTex™ Panel Installation Guide?**

Hardie™ Fine Texture Cladding  
by James Hardie is a new and  
improved exterior solution to  
create a modern render look.

Both products are compatible with  
each other and installed in accordance  
with this installation guide

# Installation Guide

Hardie™ Fine Texture Cladding

EXTERIORS

**Australia** May 2021

**Make sure your information is up to date.**

When specifying or installing James Hardie™ products, ensure that you have the current technical information and guides. If in doubt, or you need more information, visit [www.jameshardie.com.au](http://www.jameshardie.com.au) or Ask James Hardie™ on 13 11 03.

## CONTENTS

1	INTRODUCTION	2
2	SAFE WORKING PRACTICES	3
	Warning	3
	Recommended safe working practices	3
	Storage and handling	3
3	DESIGN CONSIDERATIONS	3
	Framing	4
	Fasteners	4
4	HARDIE™ FINE TEXTURE CLADDING DESIGN	5
	Recommended Accessories	5
	Alternative Accessories	5
5	PRODUCTS AND ACCESSORY DETAILS	6
	Components	6
	Fasteners, Battens and Tapes	7
6	PANEL INSTALLATION - DIRECT FIX	8
7	PANEL INSTALLATION - CAVITY FIX	9
8	CONSTRUCTION DETAILS - DIRECT FIX	10
	Junction Details	10
	External Corner Details	11
	Internal Corner Details	11
	Window Details	12
9	CONSTRUCTION DETAILS - CAVITY FIX	13
	Junction Details	13
	External Corner Details	14
	Internal Corner Details	14
	Window Details	15
10	FINISHES AND MAINTENANCE	16
	Surface Preparation	16
	Painting	16
	Maintenance	16
10	PRODUCT INFORMATION	16

Made in Australia

### SCOPE

This guide covers the use of Hardie™ Fine Texture Cladding in a residential wall application over a seasoned timber wall frame or a light-gauge steel frame installed in a vertical upright application.



## Hardie™ Fine Texture Cladding.

The beauty of clean lines and a modern render look.

Streamline the building process and deliver the modern looks and clean lines homeowners want.

Hardie™ Fine Texture Cladding is the first fibre cement cladding panel manufactured in Australia with the texture of a fine render wall.

## 1 Introduction

Hardie™ Fine Texture Cladding is a strong fibre cement pre-textured panel with a consistent fine render texture. The shiplap joint on the long edges leaves a subtle and classy V-joint. It removes the need for time-consuming set joints and specialty coatings that could be prone to cracking.

The panels are pre-sealed and flush driven brad nails remove the need for patching. Simply apply regular exterior acrylic flat paint on-site (Refer to the Finishing section on page 16 for more information).



### Renovation additions.

The texture is designed to match popular cement render making it a consistent match with the rest of the house.

### New homes and townhouses.

Mix it with other cladding products by James Hardie to achieve design diversity. It connects with Axon vertical groove cladding because it shares the James Hardie 9mm accessories.

**Specifiers.** Ensure the information in these specifications is appropriate for the application you're planning. Undertake specific design and detailing for areas which fall outside the scope of these specifications.

**Installers.** Ensure that you follow the design, moisture management and associated details and material selection provided by the designer and the Hardie™ Fine Texture Cladding Installation Guide.

### IMPORTANT NOTES

1. Failure to install, finish or maintain this product in accordance with applicable building codes, regulations, standards and James Hardie's written application instructions may lead to personal injury, affect system performance, violate local building codes, and void James Hardie's product warranty.
2. All warranties, conditions, liabilities (direct, indirect or consequential) and obligations whether arising in contract, tort or otherwise other than those specified in James Hardie's product warranty are excluded to the fullest extent allowed by law. For James Hardie's product warranty information and disclaimers about the information in this guide, visit [www.jameshardie.com.au](http://www.jameshardie.com.au).
3. The builder must ensure the product meets aesthetic requirements before installation. James Hardie will not be responsible for rectifying aesthetic surface variations following installation.

# 2 Safe Working Practices

## WARNING - DO NOT BREATHE DUST AND CUT ONLY IN WELL VENTILATED AREA

James Hardie products contain sand, a source of respirable crystalline silica. **May cause cancer if dust from product is inhaled. Causes damage to lungs and respiratory system through prolonged or repeated inhalation of dust from product.** Intact fibre cement products are not expected to result in any adverse toxic effects. The hazard associated with fibre cement arises from the respirable crystalline silica present in dust generated by activities such as cutting, rebating, drilling, routing, sawing, crushing, or otherwise abrading fibre cement, and when cleaning up, disposing of or moving dust. When doing any of these activities in a manner that generates dust, follow James Hardie instructions and best practices to reduce or limit the release of dust, warn others in the area and consider rotating personnel across the cutting task to further limit respirable silica exposure. If using a dust mask or respirator, use an AS/NZS1716 P1 filter and refer to Australian/New Zealand Standard 1715:2009 Selection, Use and Maintenance of Respiratory Protective Equipment for more extensive guidance and more options for selecting respirators for workplaces. For further information, refer to our installation instructions and Safety Data Sheets available at [www.jameshardie.com.au](http://www.jameshardie.com.au). FAILURE TO ADHERE TO OUR WARNINGS, SAFETY DATA SHEETS, AND INSTALLATION INSTRUCTIONS MAY LEAD TO SERIOUS PERSONAL INJURY OR DEATH.

### James Hardie Recommended Safe Working Practices

#### CUTTING OUTDOORS

1. Position cutting station so wind will blow dust away from the user or others in working area.
2. Warn others in the area to avoid dust.
3. Consider rotating personnel across cutting tasks to further limit respirable silica exposures.
4. Use one of the following methods based on the required cutting rate:
  - Best** ▪ Villaboard™ knife ▪ Hand guillotine ▪ Fibreshear
  - Better** ▪ Position the cutting station in a well-ventilated area. Use a dust reducing circular saw equipped with HardieBlade™ Saw Blade or comparable fibre cement blade and well maintained M-class vacuum or higher with appropriate filter for capturing fine (respirable) dust. Wear a properly-fitted, approved dust mask or respirator (minimum P1).

#### CUTTING INDOORS

- Cut only using Villaboard™ knife, hand guillotine or fibreshears (manual, electric or pneumatic).
- Position cutting station in a well-ventilated area.

#### DRILLING/OTHER MACHINING

When drilling or machining you should always wear a P1 dust mask and warn others in the immediate area.

#### IMPORTANT NOTES

1. For maximum protection (lowest respirable dust production) James Hardie recommends always using best practice cutting methods where feasible.
2. NEVER use a power saw indoors or in a poorly ventilated area.
3. ALWAYS use a dust reducing circular saw equipped with a sawblade specifically designed to minimise dust creation when cutting fibrecement - preferably a sawblade that carries the HardieBlade™ logo or one with at least equivalent performance - connected to a M class or higher vacuum.
4. NEVER dry sweep - Use wet suppression, or an M class vacuum or higher with appropriate filter.
5. NEVER use grinders.
6. ALWAYS follow tool manufacturers' safety recommendations.
7. ALWAYS wear a properly fitted, approved dusk mask, P1 or higher

#### DUST MASKS AND RESPIRATORS

As a minimum, an AS/NZS1716 P1 respirator must be used when doing any activity that may create dust. For more extensive guidance and options for selecting respirators for workplaces please refer to Australian/New Zealand Standard 1715:2009 "Selection, Use and Maintenance of Respiratory Protective Equipment". P1 respirators should be used in conjunction with the above cutting practices to minimise dust exposure. For further information, refer to Safety Data Sheet (SDS) available at [www.jameshardie.com.au](http://www.jameshardie.com.au). If concern still exists about exposure levels or you do not comply with the above practices, you should always consult a qualified industrial hygienist or contact James Hardie for further information.

## STORAGE AND HANDLING

To avoid damage, all James Hardie™ building products should be stored with edges and corners of the product protected from chipping. James Hardie™ building products must be installed in a dry state and protected from weather during transport and storage. The product must be laid flat under cover on a smooth level surface clear of the ground to avoid exposure to water, moisture, etc.

# 3 Design Considerations

All design and construction must comply with the appropriate requirements of the current National Construction Code (NCC) and other applicable regulations and standards.

## Slab and Footings

The slab and footings on which the building is situated must comply with AS 2870 'Residential slabs and footings – Construction' and the requirements of the NCC.

## Ground Clearances

Install James Hardie™ external cladding with a minimum 150mm clearance to the earth on the exterior of the building or in accordance with local building codes if greater than 150mm is required. Maintain a minimum 50mm clearance between James Hardie™ external cladding and roofs, decks, paths, steps and driveways.

Adjacent finished grade must slope away from the building in accordance with local building codes, typically a minimum slope of 50mm over the first metre.

Do not install external cladding such that it may remain in contact with standing water.

## NOTE

Greater clearance may be required in order to comply with termite protection provisions, see below for more information.

## Termite Protection

The NCC specifies the requirements for termite barriers. Where the exposed slab edge is used as part of the termite barrier system, a minimum of 75mm of the exposed slab edge must be visible to permit ready detection of termite entry.

## Structural Bracing

Hardie™ Fine Texture Cladding can be installed to provide wall bracing against lateral forces due to wind. For further information, Ask James Hardie on 13 11 03.

## Fire Rated Walls

Hardie™ Fine Texture Cladding can achieve fire ratings of 60/60/60 and 90/90/90 when constructed with additional fire rated linings as specified in James Hardie's Fire and Acoustically Rated Design Manual and Construction of Fire and Acoustically Rated Walls Technical Specification. The length of fasteners must be increased for the additional linings.

## Moisture Management

It is the responsibility of designer or specifier to identify moisture related risks associated with any particular building design. Wall construction design must effectively manage moisture, accounting for both the interior and exterior environments of the building, particularly in buildings that have a higher risk of wind driven rain penetration or that are artificially heated or cooled.

In addition, all wall openings, penetrations, junctions, connections, window sills, heads and jambs must incorporate appropriate flashing and waterproofing. Materials, components and their installation that are used to manage moisture in framed wall construction must, at a minimum, comply with the requirements of relevant standards and the NCC.

## Weather Barrier

A suitable water control membrane must be installed under James Hardie™ cladding in accordance with the AS/NZS 4200.2 'Pliable building membranes and underlays – Installation' and NCC requirements.

James Hardie has tested and certified the use of HardieWrap™ weather barrier for Climate Zones 2-8 within Australia. HardieWrap™ weather barrier is a Class 4 vapour permeable membrane that delivers a triple-shield of protection to help against external weather penetration, internal condensation management and external heat penetration through its safe-glare reflective layer.

If using an alternate product in lieu of HardieWrap™ weather barrier or the project is located in a hot, humid area (Climate Zone 1), the designer must ensure that the product is fit for purpose and it has the following classification in accordance with AS/NZS 4200.1:2017 'Pliable building membranes and underlays – Materials':

TABLE 1

Weather Barrier Classification		
Climate Zone	Water Control Classification	Vapour Control Category
2-8	Water Barrier	Vapour Permeable (Class 3 or 4)
1		Vapour Barrier (Class 1 or 2)

Soft compressible insulation installed between the front of the wall studs and directly behind the external cladding can cause installation issues and is thus not recommended.

## Flashing

All wall openings, penetrations, intersections, connections, window sills, heads and jambs must be flashed prior to cladding installation.

## FRAMING

### General

Hardie™ Fine Texture panels are installed vertically either directly fixed to frame or installed to vertically oriented Scyon™ Cavity Trim to provide a vented cavity, this can be done over either timber or steel frames. The general framing requirements for installation are given in Table 2.

Maximum stud, Scyon™ Cavity Trim and fastener spacing for Hardie™ Fine Texture panels for wind load classifications of AS 4055 'Wind Loads for Housing' are given in Table 3.

## FASTENERS

### General

All nails must be driven flush. **Before fixing to steel frame, ensure the aesthetic finish of Hardie™ Fine Texture cladding when using HardieDrive™ screws is of acceptable quality prior to installation, see Important Note 3 on page 2 of this guide. Brad nails are recommended for best aesthetic finish.** For more information and advice, Ask James Hardie™ on 13 11 03.

### Fastener Durability (Including Coastal Areas)

Fasteners must have the appropriate level of durability and be fully compatible with all other materials required for the intended project. In areas within 1km of a coastal area, areas subject to salt spray and other corrosive environments, class 4 fasteners must be used.

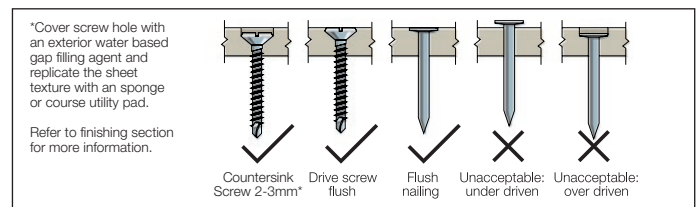

### NAIL FASTENER DEPTH

TABLE 2

General Framing Requirements				
Type	Timber		Steel	
Design	Use of timber framing must be in accordance with AS 1684 and the framing manufacturer's specifications		Use of steel framing must be in accordance with NASH standard for Residential and Low-Rise Steel Framing Part 1: Design Criteria and the framing manufacturer's specifications.	
Durability	'Timber used for house construction must have the level of durability appropriate for the relevant climate and expected service life. Reference AS 1684.2 'Residential timber-framed construction'.		The steel framing must have the appropriate level of durability required to prevent corrosion, particularly in coastal areas.	
Tolerances	Ensure frame is square and work from a central datum line. A suggested maximum tolerance of between 3mm and 4mm in any 3000mm length of frame will give best results.			
Thermal Break Requirement	Not required.		For steel frames, the NCC Sections J1.5 and 3.12.1 Volumes 1 and 2 respectively, state for both residential and commercial buildings a thermal break such as HardieBreak™ with an R 0.2m <sup>2</sup> K/W must be installed behind external cladding where the cladding and internal lining make direct contact with the same steel frame. Alternatively, off-stud vented cavity installation using Scyon™ Cavity Trim can be used in these applications.	
Framing specifications				
	Direct Fix	Cavity Fix		Cavity Fix
BMT	NA			From 0.55 to 1.6mm.
Min. Stud Width	45mm at sheet edges. 35mm at intermediates.	35mm		45mm at sheet edges. 42mm at intermediates.
Min. Stud Depth	70mm	70mm		64mm
Max. Nogging spacing	1350mm	1350mm for on stud batten fixing. 800mm for off stud batten fixing.	1350mm	

TABLE 3

Maximum Stud, Scyon™ Cavity Trim & Fastener Spacing for Hardie™ Fine Texture Cladding in AS4055 Wind Classification												
Wind Classification	General Areas of Walls (mm)					Within 1200mm of Building Edges (mm)						
	Stud Spacing	Only required for cavity fix			Sheet Fastener Spacing (Except Brad Nails)	Stud Spacing	Only required for cavity fix			Sheet Fastener Spacing (Except Brad Nails)	Sheet Fastener Spacing (Brad Nails)	
		Scyon™ Cavity Trim Spacing	Can be fixed off stud?	Scyon™ Cavity Trim Fastener Spacing			Scyon™ Cavity Trim Spacing	Can be fixed off stud?	Scyon™ Cavity Trim Fastener Spacing			
N1, N2, N3/C1	600	600	Yes	300	200	125	600	600	Yes	300	200	125
N4/C2	600	600	Yes	300	200		450	450	No	200	150	
N5/C3	600	600	No	200	200		300	300	No	200	150	
N6/C4	450	450	No	200	150		300	300	No	200	125	

NOTE: When using brad nails:

- Refer to the accessories page for brad nails options.

NOTE: Off-stud cavity installation

- When fixing Scyon Cavity Trims offstud, noggings must be spaced at 800mm maximum.

# 4 Hardie™ Fine Texture Cladding Design



**Panel Layout**  
Align horizontal and vertical joints with key building features to achieve an uninterrupted look

**Paint**  
For best results, use a roll-on, low-sheen or matt finish exterior paint in natural colours

## RECOMMENDED ACCESSORIES



NEW

### James Hardie™ 9mm External Slimline Corner

A sleek external corner that prioritises design with a sharp, minimal edge. It holds the panels tight with just 3.5mm of coverage.



NEW

### James Hardie™ 9mm Internal Concave Corner

A concave internal corner that prioritises design and perfection. Replace inconsistent sealant application with this aluminium extrusion that gives 10mm of cover.

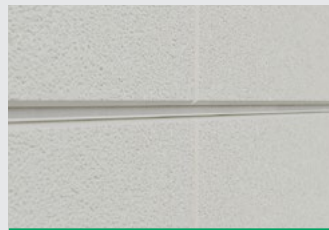

### James Hardie™ Horizontal T Flashing

A ready to paint aluminium flashing which creates a 6mm horizontal express joint while maintaining a subtle look.



### HardieEdge™ Trim

A powder coated aluminium architectural slab edge solution, which protects the bottom edge of the panel while ensure correct performance of the wall.

Suits 8.5-9mm thick fibre cement panels like Axon™ and Hardie™ Fine Texture Cladding

## ALTERNATIVE ACCESSORIES

### External Corners

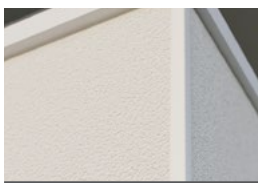

### James Hardie™ 9mm External Corner

Aluminium extrusion that creates a square edge in external corner.

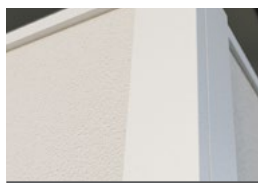

### External Corner using Axent™ Trim

External corner created with 2 Axent™ Trims 45x19mm.

### Internal Corners

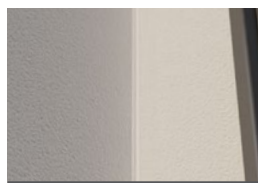

### James Hardie™ 9mm Internal Corner

Aluminium extrusion that creates an internal box corner.

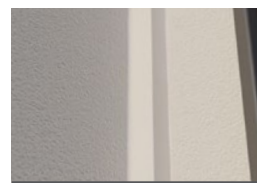

### Internal Corner using Axent™ Trim

Internal corner created with 1 Axent(tm) Trims 45x38mm.

### Horizontal Joiner



### James Hardie™ Horizontal h Flashing

Aluminium extrusion used along horizontal joints to conceal the panel edge.

# 5 Products and Accessory Details

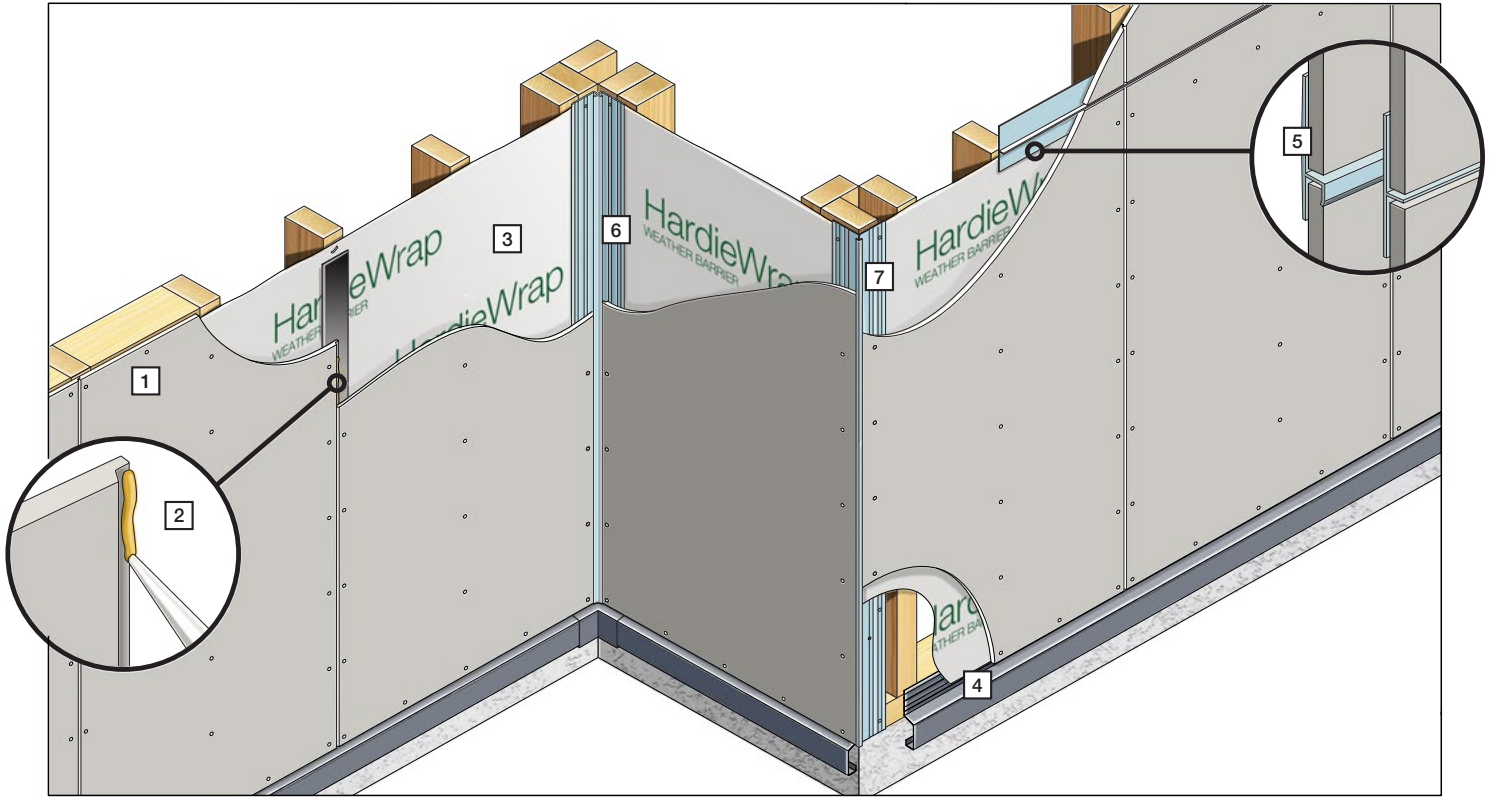

## COMPONENTS

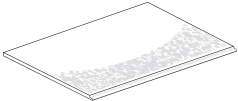
1	Hardie™ Fine Texture Cladding (8.5mm thick)	Product Code	Length (mm)	Width (mm)	Mass (kg)	Pack Size
 <p>Pre-sealed and ready to paint textured sheet with a ship-lapped V-Groove joint along the two vertical edges.</p>		405252	2440	1200	36	40
		405255	2750	1200	41	40
		405253	3000	1200	44	40
		405254	3600	1200	52	30

### 2 James Hardie™ Joint Sealant



General purpose polyurethane exterior grade joint sealant.  
Pack Size: 20/Box.  
Product Code: 305534 300ml Cartridge  
Product Code: 305672 600ml Sausage  
Coverage: 2.67m/100ml (5mm dia bead)

### 3 HardieWrap™ Weather Barrier



High water barrier and vapour permeable membrane.  
Unit size: 2.75 x 30m. Pack Size: 1 Each. Product Code: 305664  
Coverage: 85.5m<sup>2</sup> per roll

### 4 HardieEdge™ Trim



Powder coated aluminium architectural slab edge solution. Product Codes:  
HardieEdge™ Trim (4/pack) 305911  
Base Trim Joinder (12/pack) 305912  
Internal Corner (4/pack) 305913  
External Corner (4/pack) 305914

## Horizontal Flashing Options

### 5 James Hardie™ Horizontal T Flashing

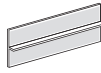

Sheet joiner that creates a subtle look.  
Product Code: 306040  
T flashing 3000mm (5/pack)  
Coverage: Length of horizontal joints / 3000mm

### 5 James Hardie™ Horizontal h Flashing

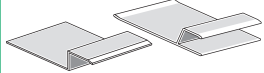

Aluminium extrusion used along horizontal control joints. Product Codes:  
h flashing 3000mm (5/pack) 305613  
h flashing joinder (10/pack) 305614  
Coverage: Length of horizontal joints / 3000mm

## External Corner Options

### 6 James Hardie™ 9mm External Corner



Aluminium extrusion to be used in external corners.  
3000mm long. Pack Size: 5  
Product Code: 305521  
Coverage: Height of wall x no. of external corners / 3000mm

### 6 James Hardie™ 9mm External Slimline Corner

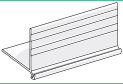

**NEW**  
Aluminium extrusion that creates a minimalist edge.  
Product Code: 306102  
Coverage: Length of horizontal joints / 3000mm

## Internal Corner Options

### 7 James Hardie™ 9mm Internal Concave Corner

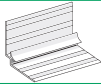

**NEW**  
Aluminium extrusion that replicates the traditional sealant bead look.  
Product Code: 306103  
Coverage: Length of horizontal joints / 3000mm

### 7 James Hardie™ 9mm internal Corner

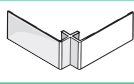

Aluminium extrusion that creates a box corner.  
3000mm long. Pack Size: 5  
Product Code: 305520  
Coverage: Height of wall x no. of internal corners / 3000mm

## Alternative Corner Options

### 8 James Hardie™ Corner Flashing

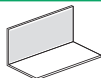

Manufactured using COLORBOND® steel, used behind cladding at internal and external corners. 75 x 75mm.  
3000mm long.  
Pack Size: 5. Product Code: 305564  
Coverage: Height of clad walls x no. of corners / 3000mm

### 9 Scyon™ Axent™ Trim







Material composite trim used for box corners and for trim around windows and doors. Pack Size: 1.  
For internal corners: 45 x 38mm.  
4200mm long. Product Code: 403626  
For external corners: 45 x 19mm.  
4200mm long. Product Code: 404662

# 5 Products and Accessory Details cont.





## FASTENERS, BATTENS AND TAPES

Hardie™ Fine Texture Cladding can be fixed either to timber or steel frames, which can be done directly or over Scyon™ cavity trim. Depending on the fixing method and substructure, there will be different components required, these are:



### OPTION 1: DIRECT FIX - TIMBER FRAME

	<p><b>8 James Hardie™ Foam Back Sealing Tape</b></p>  <p>Installed under sheet vertical joints to improve water tightness. 50mm wide 25mtr long roll. Pack Size: Each Product Code: 304560</p>	<p><b>9 ND 50mm Stainless Steel Brad Nail*</b></p>  <p>14 gauge x 50mm ND 304 stainless steel nail for fixing Hardie™ Fine Texture panels to timber framing. Not supplied by James Hardie™.</p>	<p><b>Gun Nail*</b></p>  <p><b>Only required in high wind areas.</b> 2.8 x 40mm minimum class 3 nail with a minimum 6mm head diameter to be used with gun nails. Not supplied by James Hardie™.</p>	<p><b>Fibre Cement Nail*</b></p>  <p><b>Only required in high wind areas.</b> 2.8 x 30mm corrosion resistant fibre cement nail for fixing panels onto timber stud frame. Not supplied by James Hardie™.</p>
--	---	--	--	--

### OPTION 2: CAVITY FIX - TIMBER FRAME

	<p><b>12 Scyon™ Cavity Trim</b></p>  <p>Fibre cement trim used to fix external cladding to steel or timber frame. Size: 70 x 19 x 2450mm. Pack Size: 96 Product Code: 403840</p>	<p><b>13 Gun Nails to fix trim to frame*</b></p>  <p>2.8 x 65mm long ring shank nail or 75 x 2.8mm D or round head galvanised smooth shank nail used to fix Scyon™ cavity trim to timber stud. Not supplied by James Hardie™.</p>	<p>Fastener to fix Hardie™ Fine Texture Cladding to Scyon™ Cavity Trim</p>		<p><b>14 25mm DA Brad Nails*</b></p>  <p>25mm DA 16 gauge 304 stainless brad nails. Not supplied by James Hardie™.</p>	<p><b>14 Fibre Cement Nail*</b></p>  <p><b>Only required in high wind areas.</b> 2.8 x 30mm corrosion resistant fibre cement nail. Not supplied by James Hardie™.</p>
--	---	--	--	--	---	--

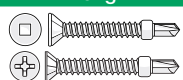
### OPTION 3: CAVITY FIX - STEEL FRAME Only suitable in wind classifications up to N3/C1

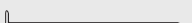
	<p><b>12 Scyon™ Cavity Trim</b></p>  <p>Fibre cement trim used to fix external cladding to steel or timber frame. Size: 70 x 19 x 2450mm. Pack Size: 96 Product Code: 403840</p>	<p><b>15 HardieDrive™ Screw 41mm long*</b></p>  <p>A class 3 self-tapping wing-tipped screw for fastening to 0.5mm to 1.6mm BMT light gauge steel frames. 1000 per box. Product Codes: 305984 (loose) 305982 (collated)</p>	<p>Fastener to fix Hardie™ Fine Texture Cladding to Scyon™ Cavity Trim</p>		<p><b>14 25mm Stainless DA Brad Nails*</b></p>  <p>25mm DA 16 gauge 304 stainless brad nails. Not supplied by James Hardie™.</p>	<p><b>14 Fibre Cement Nail*</b></p>  <p><b>Only required in high wind areas.</b> 2.8 x 30mm corrosion resistant fibre cement nail. Not supplied by James Hardie™.</p>
--	---	--	--	--	---	--

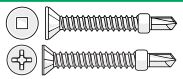

### OPTION 4: DIRECT FIX - STEEL FRAME

	<p><b>10 HardieBreak™ Thermal Strip</b></p>  <p>Refer to the HardieBreak™ Thermal Strip install guide. NCC requirement used behind external cladding when fixed directly to steel frame. Size: 43 x 12 x 2750mm. 45 per pack. Product Code: 305612</p>	<p><b>11 HardieDrive™ Screw 41mm long*</b></p>  <p>A class 3 self-tapping wing-tipped screw for fastening to 0.5mm to 1.6mm BMT light gauge steel frames. 1000 per box. Product Codes: 305984 (loose) 305982 (collated)</p>
--	---	--

#### Accessories

<p><b>Exterior Water Based Gap Filling Agent</b></p>  <p>Recommended sealers include Selleys® No More Gaps - Exterior/Weatherboard or Polyfilla® - Large Cracks</p>
--

#### Tools

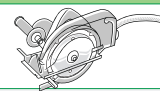
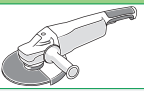
<p><b>Sponge or course Utility Pad</b></p>  <p>Used with recommended external based filling agent to match the panel texture finish.</p>	<p><b>HardieBlade™ Saw Blade 185mm Diameter</b></p>  <p>Poly-diamond blade for James Hardie™ fibre cement. Product Code: 300660 Pack Size: 1 each.</p>	<p><b>Dust-Reducing Saw with M class or higher vacuum Extraction</b></p>  <p>Dust reducing saw with a HardieBlade™ saw blade. Makita 5057KB / Hitachi C7YA.</p>	<p><b>Angle Grinder*</b></p>  <p>9inch angle grinder with a Masonry or Diamond Disk. *Not to be used for cutting the Hardie™ Fine Texture Panels</p>
---	---	--	---

† All dimensions and masses are approximate and subject to manufacture tolerances.

\* In coastal areas and other corrosive environments class 4 fasteners must be used. All other areas require minimum class 3.

# 6 Panel Installation Process\* - Direct Fix

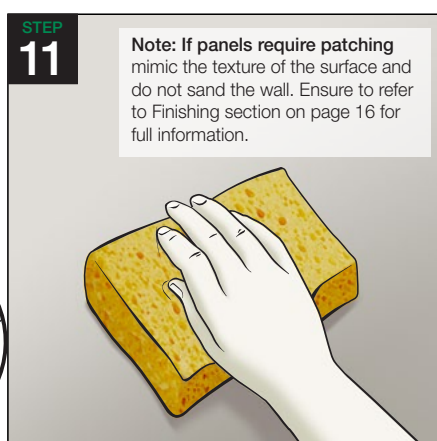
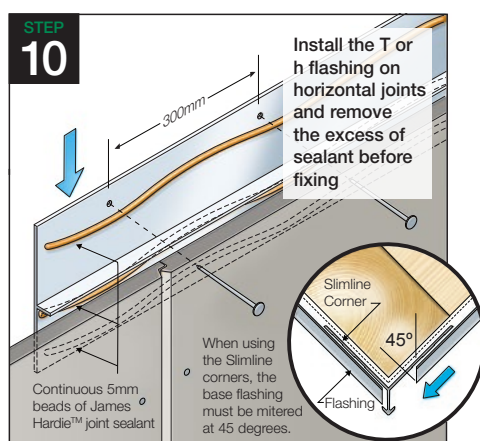
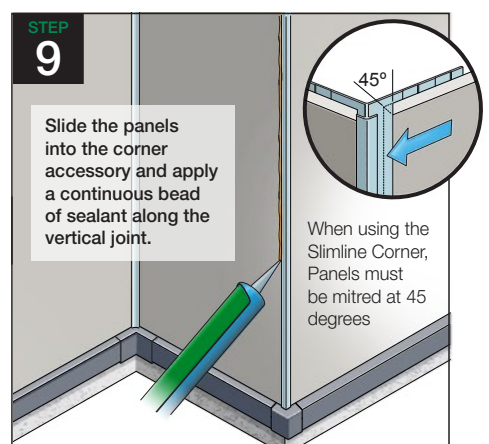
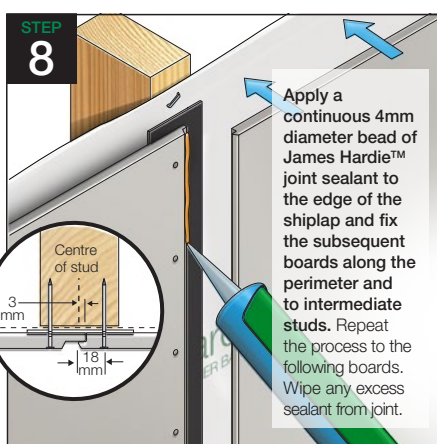
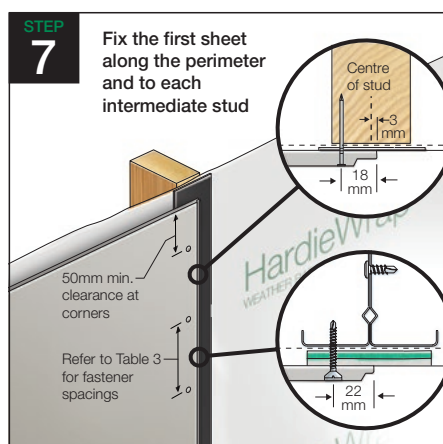
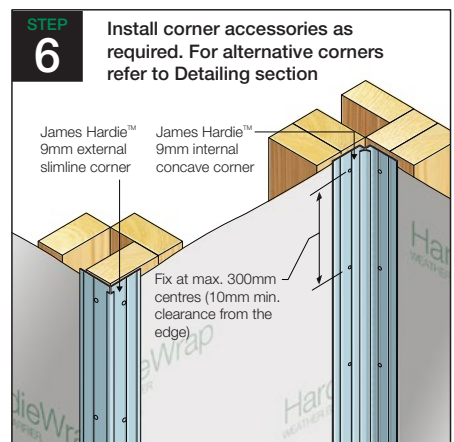
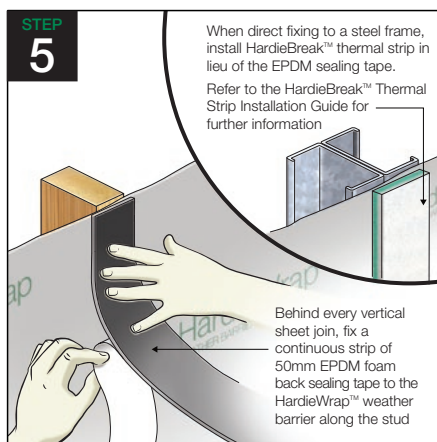
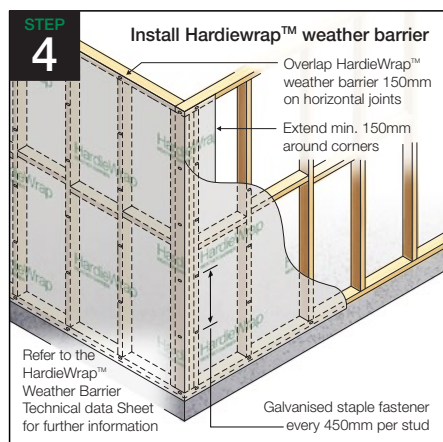
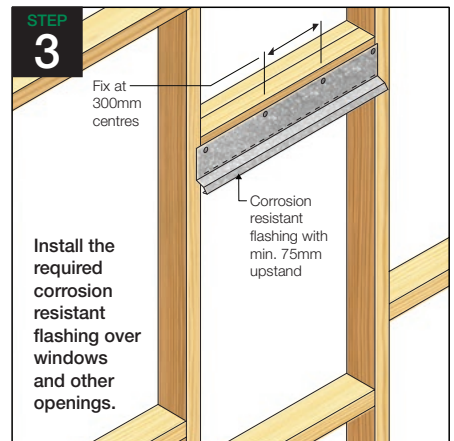
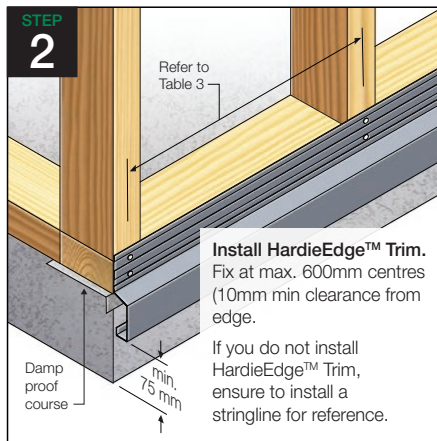
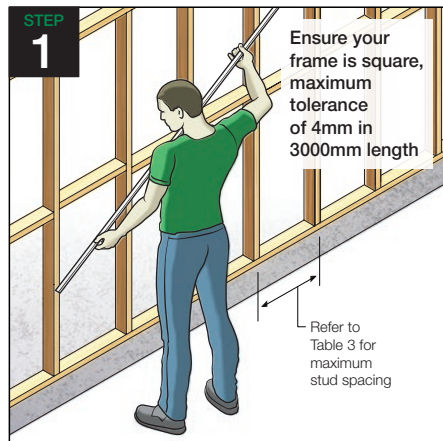

\*This is an overview of the installation process only. It is not a substitute for reviewing this document in its entirety prior to installation.



# 7 Panel Installation Process\* - Cavity Fix

**STEP 1** Ensure your frame is square, maximum tolerance of 4mm in 3000mm length

Max. 800mm centres when fixing cavity trims off-stud

Refer to Table 3 for maximum stud spacing

**STEP 2** Install the required corrosion resistant flashing over windows and other openings.

Fix at 300mm centres

Corrosion resistant flashing with min. 75mm upstand

**STEP 3** Install Hardiewrap™ weather barrier

Overlap Hardiewrap™ weather barrier 150mm on horizontal joints

Extend min. 150mm around corners

Refer to the Hardiewrap™ Weather Barrier Technical data Sheet for further information

Galvanised staple fastener every 450mm per stud

**STEP 4** Install the James Hardie™ PVC cavity vent Strip

Fix at 600mm centres maximum, with 10mm edge clearance.

James Hardie™ PVC cavity vent mitred at corners and kept clear of debris. Do not insert Scyon™ cavity trim into the vent strip

Damp proof course

10 mm

min. 150 mm

**STEP 5** Install the cavity trims (must be fixed off-stud in steel frames)

45° cut

James Hardie Joint Sealant

50

50

Scyon™ cavity trim

20 mm min.

Refer to Table 3 for fastener spacing

**STEP 6** Install corner accessories as required. For alternative corners refer to Detailing section

James Hardie™ concave internal corner

Scyon™ cavity trim

James Hardie™ 9mm slimline external corner

Fix at max. 300mm centres (10mm min. clearance from the edge)

**STEP 7** Fix the first sheet along the perimeter and to each intermediate stud

50mm min. clearance at corners

Refer to Table 3 for fastener spacings

18 mm

**STEP 8** Apply a continuous 4mm diameter bead of James Hardie™ joint sealant to the edge of the shiplap

Bead of James Hardie™ joint sealant

**STEP 9** Fix the subsequent boards along the perimeter and to intermediate studs. Repeat the process to the following boards. Wipe any excess sealant from joint.

When using the Slimline corners, panels must be mitred at 45 degrees.

45°

18 mm

**STEP 10** Install the T or h flashing on horizontal joints and remove the excess of sealant before fixing

300mm

Continuous 5mm beads of James Hardie™ joint sealant

When using the Slimline corners, the base flashing must be mitred at 45 degrees.

Slimline Corner

45°

Flashing

**STEP 11** Note: If panels require patching mimic the texture of the surface and do not sand the wall. Ensure to refer to Finishing section on page 16 for full information.

**STEP 12** Paint the wall with an exterior acrylic paint within 3 months of being fixed or within 7 days if located within 1km of a coastal area or corrosive environment

Refer to Finishing section on page 16 for more information.

\*This is an overview of the installation process only. It is not a substitute for reviewing this document in its entirety prior to installation.

# 8 Construction Details - Direct Fix

## JUNCTION DETAILS

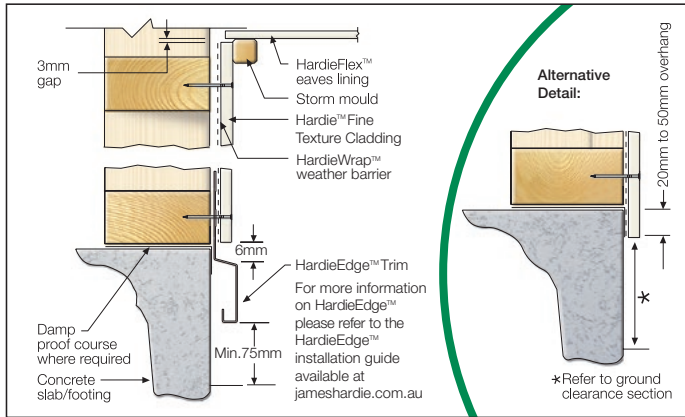

FIGURE 1 SLAB/EAVE JUNCTION DETAIL

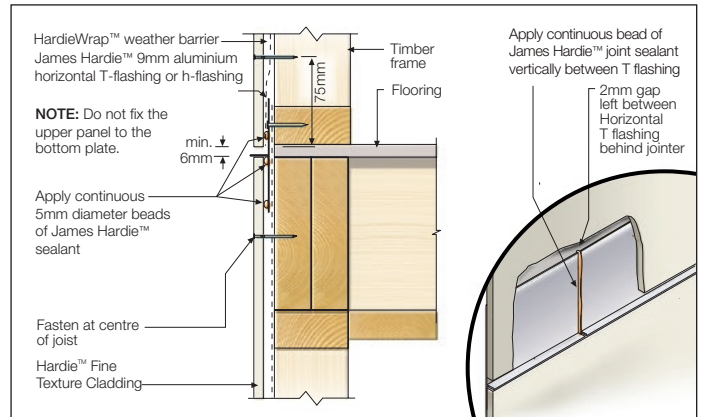

FIGURE 2 UPPER FLOOR JUNCTION OPTION 1

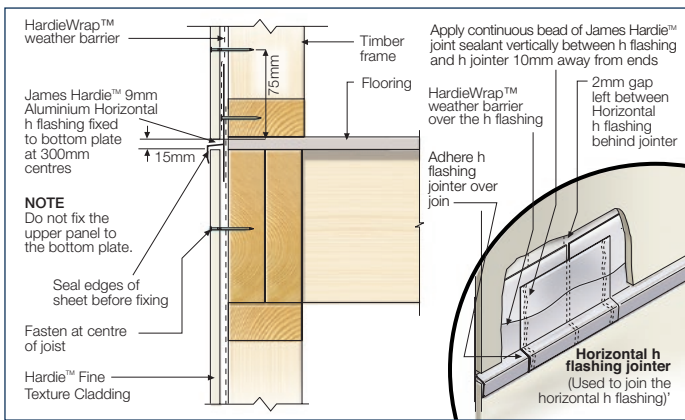

FIGURE 3 UPPER FLOOR JUNCTION OPTION 2

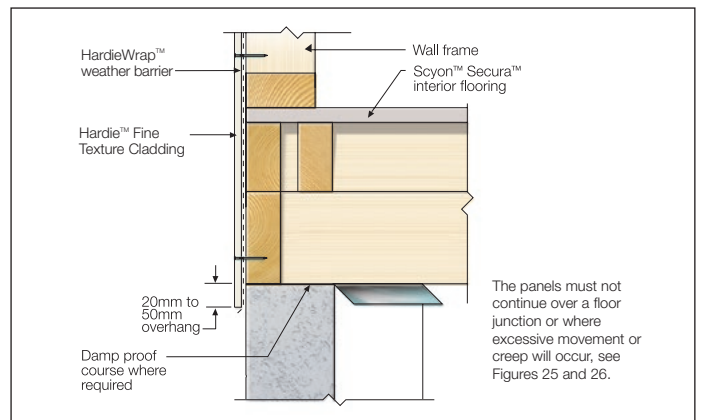

FIGURE 4 LOWER FLOOR JUNCTION

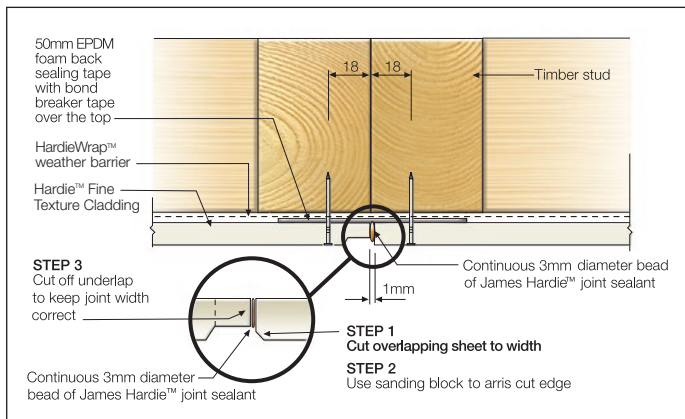

FIGURE 5 VERTICAL BUTT JOINT

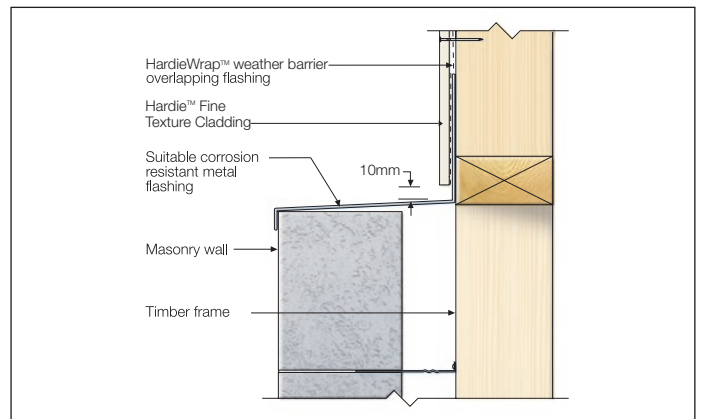

FIGURE 6 HORIZONTAL JUNCTION 2

**NOTE:** Join the James Hardie 9mm Aluminium Horizontal h flashings on intermediate studs and not off stud or behind sheet joints.

## EXTERNAL CORNER DETAILS

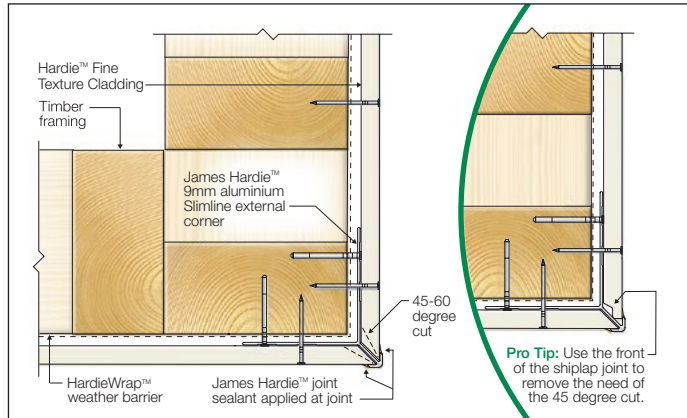

FIGURE 7 SLIMLINE CORNER OPTION

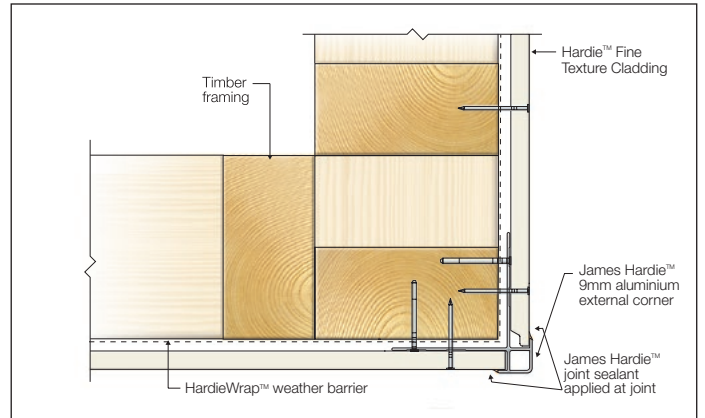

FIGURE 8 ALUMINIUM BOX CORNER OPTION

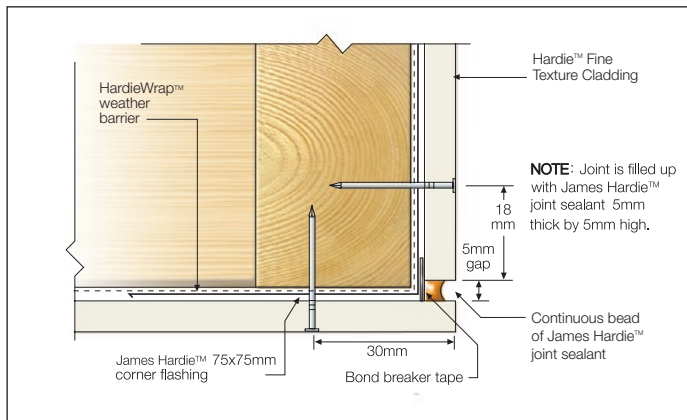

FIGURE 9 SEALANT FILL OPTION

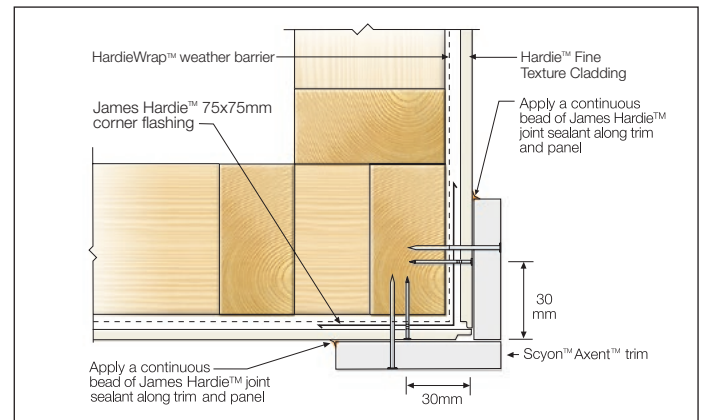

FIGURE 10 TRIM CORNER OPTION

## INTERNAL CORNER DETAILS

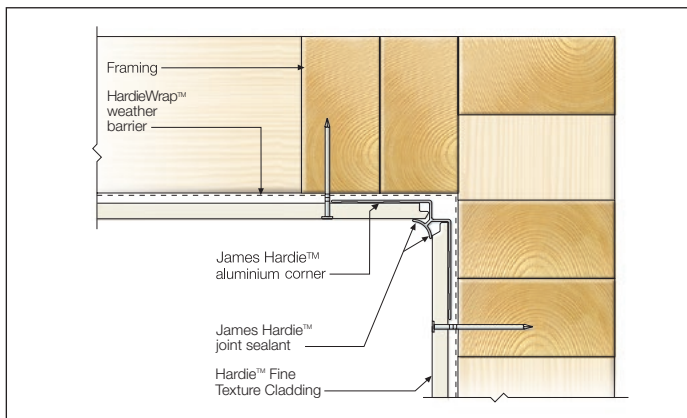

FIGURE 11 ALUMINIUM CORNER DETAIL

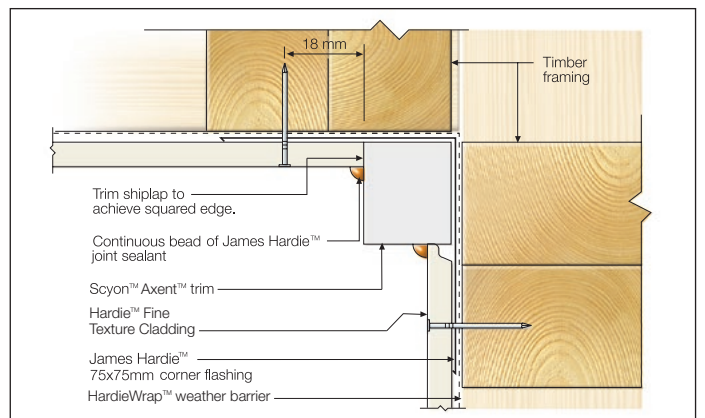

FIGURE 12 TRIM CORNER OPTION

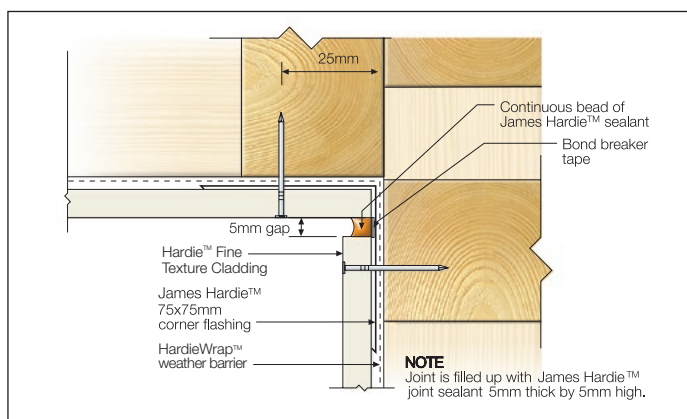

FIGURE 13 SEALANT FILL OPTION

## WINDOW DETAILS

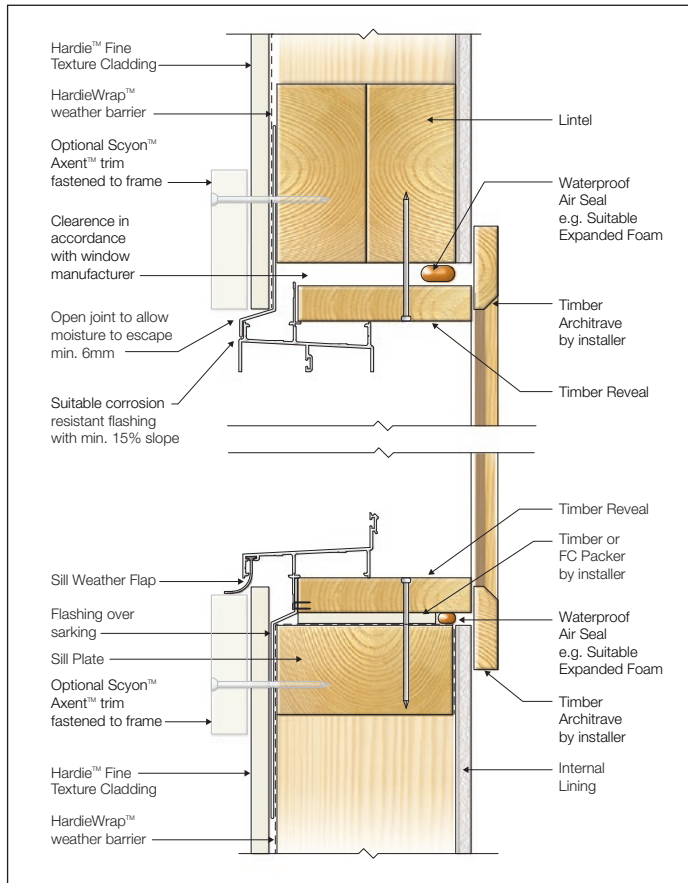

FIGURE 14 WINDOW HEAD AND SILL - TRIM

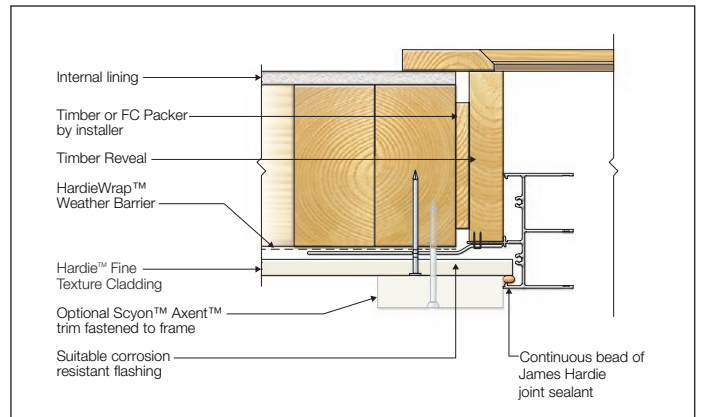

FIGURE 15 WINDOW JAMB - TRIM

# 9 Construction Details - Cavity Fix

## JUNCTION DETAILS

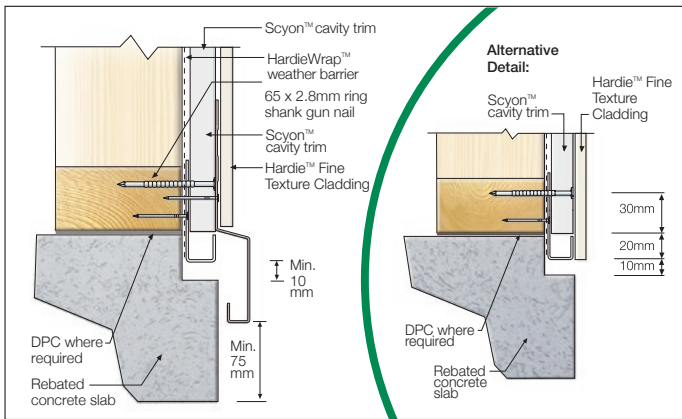

FIGURE 16 ALTERNATIVE SLAB EDGE DETAILS

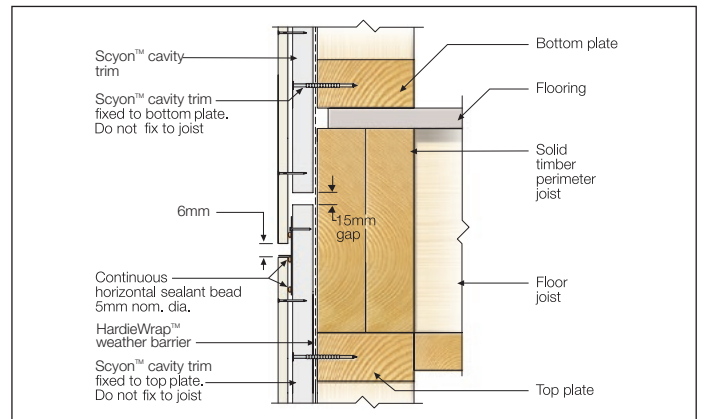

FIGURE 17 FLOOR LEVEL JUNCTION T-FLASHING OPTION

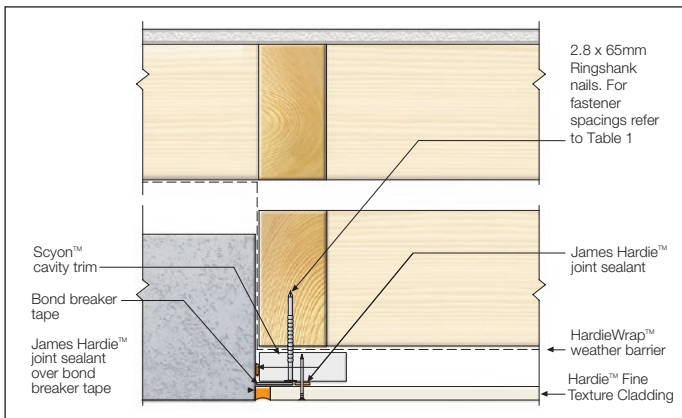

FIGURE 18 ABUTMENT DETAIL

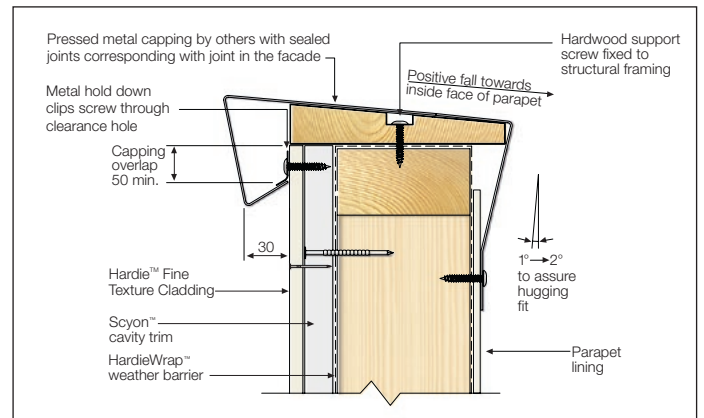

FIGURE 19 PARAPET CAPPING DETAIL

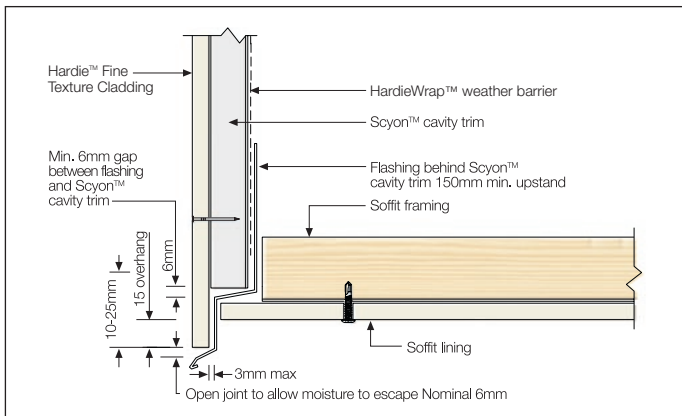

FIGURE 20 FACADE/SOFFIT JUNCTION

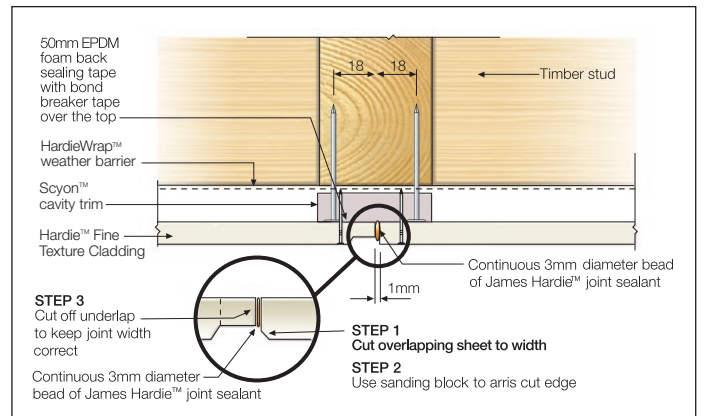

FIGURE 21 VERTICAL BUTT JOINT

## EXTERNAL CORNER DETAILS

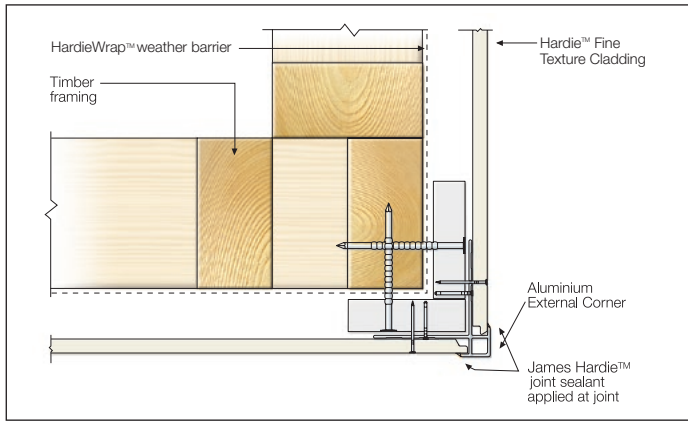

FIGURE 22 ALUMINIUM BOX CORNER OPTION - CAVITY TRIM

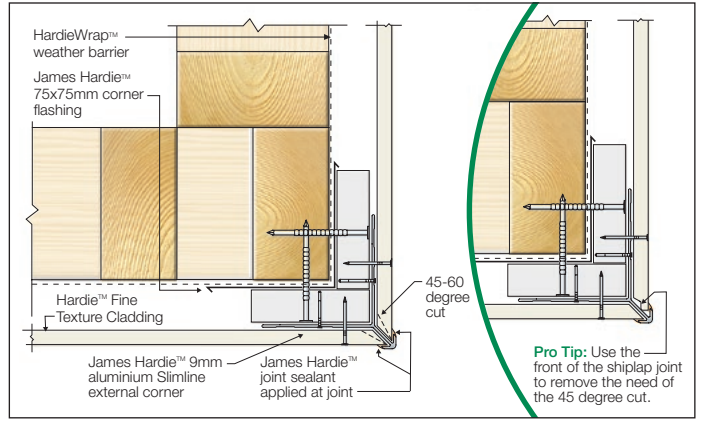

FIGURE 23 SLIM CORNER OPTION - CAVITY TRIM

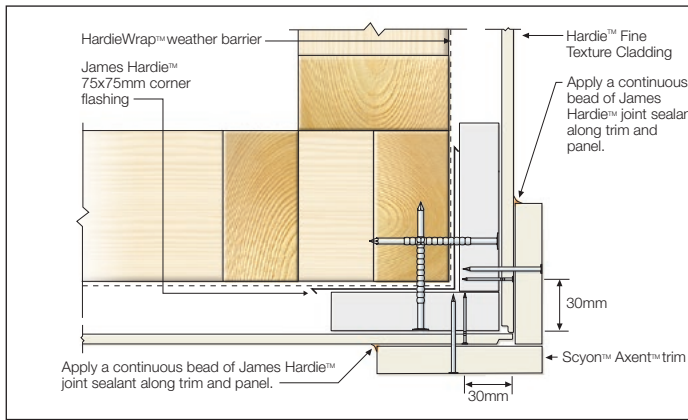

FIGURE 24 TRIM CORNER OPTION - CAVITY TRIM

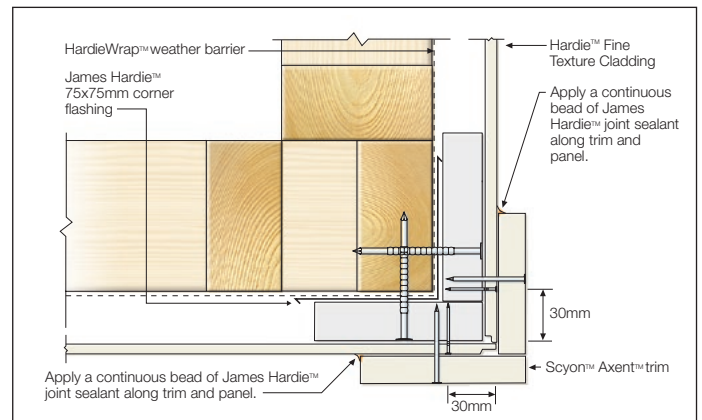

FIGURE 25 TRIM CORNER OPTION - CAVITY TRIM

## INTERNAL CORNER DETAILS

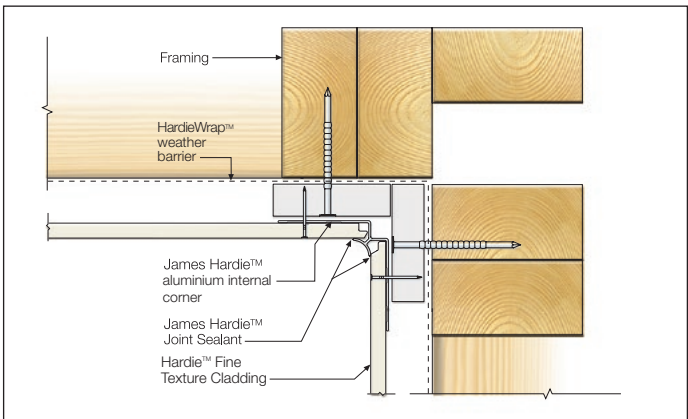

FIGURE 26 ALUMINIUM CORNER DETAIL - CAVITY TRIM

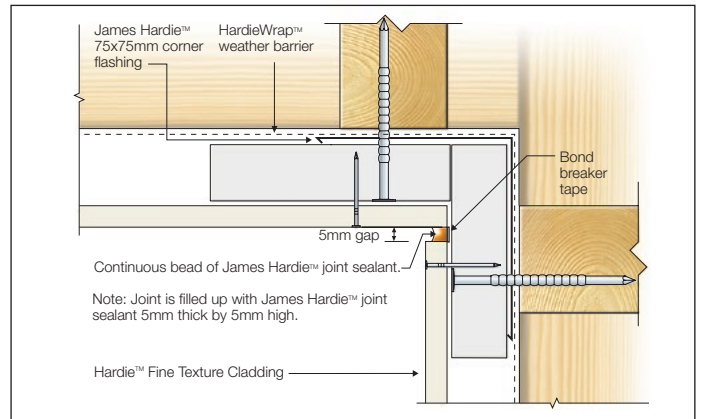

FIGURE 27 SEALANT FILL OPTION - CAVITY TRIM

# WINDOW DETAILS

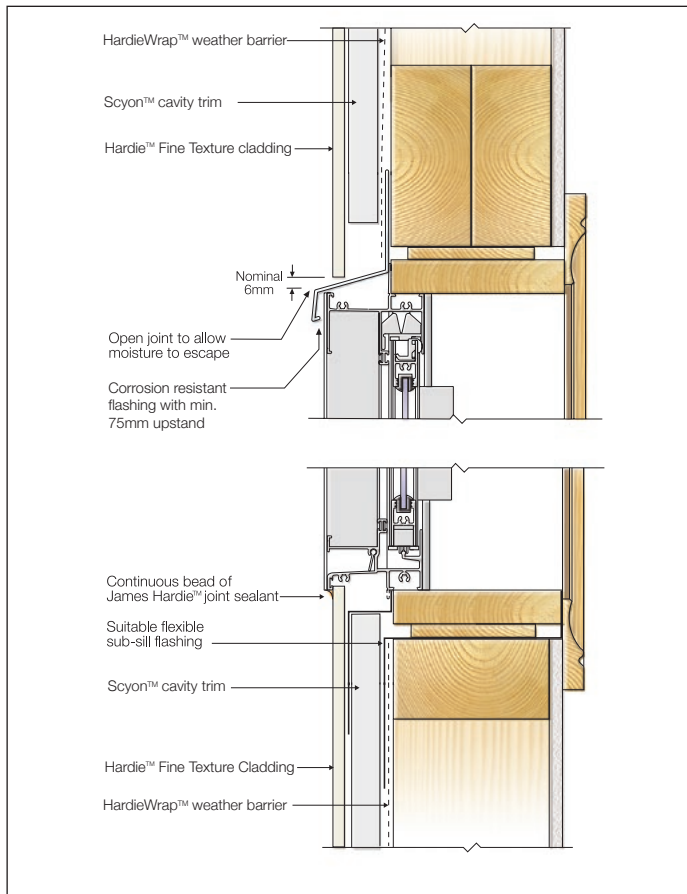

FIGURE 28 WINDOW HEAD AND SILL - CAVITY TRIM

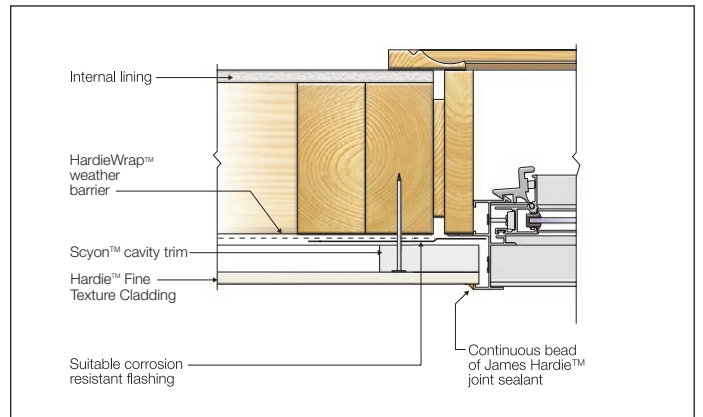

FIGURE 29 WINDOW JAMB - CAVITY TRIM

# 10 Finishes and Maintenance

## SURFACE PREPARATION

Ensure the surface is dry, clean and any overdriven nails are patched in accordance with this specification.

Any slightly overdriven brad nails (1mm max.) may be repaired using a suitable external grade filling agent and blended with the surrounding texture using a sponge or utility pad if required.

### Sealants

James Hardie recommends the use of James Hardie™ joint sealant, which is a paintable polyurethane sealant. Use of alternative sealants must comply with manufacturer's instructions. Sealants, if coated, must be compatible with the paint system.

## PAINTING

Panels must be finished within 3 months of being fixed with the recommended coating set out in Table 4 and the project specification. In areas within 1km of a coastal area or corrosive environment, panels must be coated immediately after fixing sheets to minimise contamination build up on the heads of the fasteners.

TABLE 4

Hardie™ Fine Texture Cladding Finishing Requirements	
Flat Acrylic Paints	✓ Exterior acrylic flat paint. A nap roller of 12mm or greater is recommended for optimal finish. For best results, use low-sheen or matt finish exterior paints in natural colours.
Roll-On Texture Paints (1-2mm)	✗ Panels are pre-textured, they are not compatible with textured paints.
Stains & Clear Sealers	✗ Semi-transparent stains can vary in uniformity of appearance depending on method of application and conditions and will require a high level of skill and craftsmanship to achieve a uniform appearance. Clear coats have not proven durable in exterior exposure and James Hardie™ considers them a maintenance item that may require application of a refurbishing sealer at regular intervals. James Hardie does not warrant the appearance or durability of semi-transparent stains and clear coats.

## MAINTENANCE

The extent and nature of maintenance will depend on the geographical location and exposure of the building. As a guide, it is recommended that basic normal maintenance tasks shall include but not be limited to:

- Washing down exterior surfaces every 6-12 months\*
- Periodic inspections should be made to ensure fasteners are adequately securing the sheets to framing.
- Re-applying of exterior protective finishes\*
- Maintaining the exterior envelope and connections including joints, penetrations, flashings and sealants that may provide a means of moisture entry beyond the exterior cladding.
- Cleaning out gutters, blocked pipes and overflows as required.
- Pruning back vegetation that is close to or touching the building.

\*Refer to your paint manufacturer for washing down and recoating requirements related to paint performance.

# 11 Product Information

## PRODUCT INFORMATION

### Material

The basic composition of James Hardie™ building products is Portland cement, ground sand, cellulose fibre, water and proprietary additives.

James Hardie™ building products are manufactured to AS/NZS 2908.2 'Cellulose-Cement Products-Flat Sheet'. These are also compliant with equivalent standard ISO 8336 'Fibre-cement flat sheets - Product specification and test methods'. For product classification refer to the relevant Physical Properties Data Sheet.

### Durability

#### Resistance to Moisture/Rotting

Hardie™ Fine Texture Cladding have demonstrated resistance to permanent moisture induced deterioration (rotting) by passing the following tests in accordance with AS/NZS 2908.2:

- Water permeability (Clause 8.2.2)
- Heat rain (Clause 6.5)
- Warm water (Clause 8.2.4)
- Soak dry (Clause 8.2.5)

#### Resistance to fire

The Hardie™ Fine Texture Cladding is suitable where non-combustible materials are required in accordance with C1.9 of the National Construction Code (NCC).

James Hardie™ building products have been tested by CSIRO in accordance with AS/NZS 3837 and are classified as conforming to Group 1 material (highest and best result possible), with an average specific extinction area far lower than the permissible 250m<sup>2</sup>/kg, as referenced in Specification C1.10a of the National Construction Code (NCC).

#### Resistance to Termite Attack

Based on testing completed by CSIRO Division of Forest Products and Ensis Australia James Hardie™ building products have demonstrated resistance to termite attack.

### Alpine Regions

In regions subject to freeze/thaw conditions, all James Hardie fibre cement external cladding must be installed and painted in the warmer months of the year where the temperature does not create freeze and thaw conditions or paint issues. The cladding must be painted immediately after installation. In addition, fibre cement cladding must not be in direct contact with snow and/or ice build up for extended periods, e.g. external walls in alpine regions subject to snow drifts over winter.

Furthermore, a reputable paint manufacturer must be consulted in regards to a suitable product, specifications and warranty. The paint application must not be carried out if the air temperature or the substrate temperature is outside the paint manufacturer's recommendation including the specified drying temperature range

James Hardie™ external cladding products are tested for resistance to frost in accordance with AS/NZS 2908.2 Clause 8.2.3.





**For information and advice  
call 13 11 03 | [jameshardie.com.au](https://www.jameshardie.com.au)**

**Australia May 2021**

© 2021 James Hardie Australia Pty Ltd ABN 12 084 635 558  
™ and ® denote a trademark or registered mark owned by James Hardie Technology Limited.  
Colorbond®, Selleys®, Polyfilla®, Megapoxy®, Hitachi®, Makita®, Dulux®, Taubmans®, Watty® and Hilti are trademarks  
or registered trademarks of their respective owners and are not owned by James Hardie Technology Limited.

