

**Promat**



STRUCTURAL PROTECTION

# PROMATECT<sup>®</sup> -XS

Second Generation Fire Protective Board

Providing fire protection to structural steel for up to 120 minutes



**FULLY CERTIFIED**  
AT LIMITING TEMPERATURES  
FROM 300°C TO 750°C

**CAN BE INSTALLED  
BEFORE THE BUILDING  
IS WEATHERTIGHT**

**High performing  
fire protection  
board with excellent  
weather resistance  
and fast installation**

# Promat is the global leader in passive fire protection

We offer you a complete portfolio of certified and tested products and systems to design and build a fully reliable fire safety solution for your building project.

With more than 60 years of experience and know-how, we are ready to help you protect people, buildings and assets.

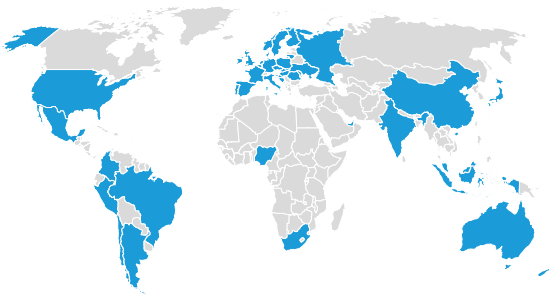

---

## OUR MISSION

We want to make the world safer, healthier and more sustainable for the generations of today and tomorrow.

Safety is a concept people need in order to grow, prosper and enjoy life, yet we take it for granted every day. This is why we offer the highest standard in fire safety for homes, offices, schools, hospitals, shopping malls and airports.

As the way we live, work and build constantly evolves, Promat wants to help maintain the highest level of fire safety. We offer you new products and innovations, so together, we can make this world a safer place.





**PROMATECT®-XS is a fire protective board which can provide up to 120 minutes fire-resistance to structural steel**



PROMATECT®-XS has permanent dimensional stability, so in the event of a fire it reduces the speed at which the steelwork will heat up, allowing it to maintain its load bearing capacity for longer.

PROMATECT®-XS is manufactured at our Etex manufacturing plant in Germany. The plant works to ISO 9001, ISO 14001 and ISO 45001 standards.



**UP TO 120 MINUTES  
FIRE PROTECTION**



**MOISTURE  
RESISTANT**

# Product Overview

PROMATECT®-XS is used to provide one, two, three or four sided encasements to:

- Universal columns and beams (I or H sections) and joists
- Beams supporting composite floors with profiled metal decking
- Structural hollow sections
- Partially exposed members
- Perimeter beams
- Lattice beams
- Wind posts
- Bracing

PROMATECT®-XS is a high performance, water repellent, fire protection board with superior weather protection.

## Benefits

- Dimensionally stable
- Quick, easy to cut and install saving time and reducing installed cost
- Frameless system minimises space
- No requirement for adhesive or joint fillers
- Smooth, impact resistant surface
- Water, weather and mould resistant
- **Can be installed before the building is weathertight (up to 6 months semi-exposed).\***
- **Certified to AS 4100 and AS 1530.4:2014**
- High levels of fire protection to structural steelwork.



PROMATECT®-XS can be installed before the building is weathertight.

*\*To protect from driving rain it is recommended that a bead of external grade fire-resistant sealant is applied at the cut edges after the boards are butted together and smoothed over the joint and exposed edge rather than applying between the edges and squeezing together.*





**PROMATECT®-XS is typically used:**

- In any project where there is a requirement for up to 120 minutes fire protection
- In the early construction phase when the building is not weathertight
- Where space is limited, and speed of installation is important.

# Design Benefits

## Fully tested and certified

Since the Grenfell tragedy, the performance of building materials is under an unprecedented spotlight.

Promat is driven by an uncompromising attitude to fire protection. Specifiers can be confident of the performance of PROMATECT®-XS due to it being fully tested and fit for purpose.

### PROMATECT®-XS is:

- Manufactured by the Etex Group under ISO 9001, ISO 14001 and ISO 45001 conditions and is thus fully traceable.
- Tests carried out by official laboratories with random product selection, manufacturing plant under third party factory production control.
- Also tested as part of a whole system to assess its interaction with other building components.
- Certified in accordance with AS1530.4:2014 and AS4100.
- The steel columns and beams encasement does not require any additional substructure, which significantly increases the efficiency of the solution and reduces the assembly costs.
- Quick and simple installation using staples and wedge soldiers, no steel angles nor metallic clips required.
- Lightweight - the low weight of the system (panels) improves the speed and safety of the installation.
- Maintenance and repairs system tested and approved in fire condition.

### THIRD PARTY CERTIFICATION



PROMATECT®-XS has been independently assessed by WarringtonFire FAS230021.

### 'REAL LIFE' TESTING



Promat products are tested as part of a whole system, not just as a product, to assess their interaction with other building components.

### RAW MATERIALS



All of the raw materials used by the Etex Group have been responsibly sourced from its trusted suppliers.

### MANUFACTURE



Manufactured within the Etex Group under ISO 9001, ISO 14001 and ISO 45001 conditions.

### FULLY TRACEABLE



Our products and processes are fully traceable.





# Design Benefits

## Performance

PROMATECT®-XS provides a clean, impact resistant finish and is used where the fire protection system is in full view and where it is hidden.

It offers the specifier a clean, boxed appearance and can be applied on unpainted steelwork. It is often a thinner solution in comparison with other fire-resistant constructions.

It can also accept a decorative finish and therefore be used where aesthetics are important.

**CAN BE INSTALLED BEFORE THE BUILDING IS WEATHERTIGHT\***  
CONTACT PROMAT FOR MORE DETAILS.

*\*To protect from driving rain it is recommended that a bead of external grade fire-resistant sealant is applied at the cut edges after the boards are butted together and smoothed over the joint and exposed edge rather than applying between the edges and squeezing together.*

### FIRE RESISTANT



Non-combustible compliant under to NCC C1.9/C2D10.

### MOISTURE RESISTANT



Can be installed before the building is weathertight\*.

### MOULD RESISTANT



Resistant to the effects of moisture.

### COMPREHENSIVELY STRONG



Galvanised steel partition sections can be installed directly up to the face of the board.

### FLEXIBLE



PROMATECT®-XS is often a thinner solution in comparison to other fire-resistant constructions.

### DURABLE



PROMATECT®-XS will not degrade by age and has good impact strength.

### EASY TO DECORATE



With a smooth, decorative finish.







# General principles for structural steel protection

## General

Building Regulations require certain elements of structures to have fire resistance for a specified minimum period of time.

Steel is an increasingly essential building material. It is classified non-combustible without special certification, but structural steel loses a significant portion of its loadbearing capacity when it reaches a temperature of approximately 500-600°C.

Steel structures are designed according to AS4100. One of the most important pieces of data is the critical temperature of each element of the steel structure. Critical temperature can vary between 350 and 750°C, depending how much of the members total load capacity is being utilised in a particular application.

During many actual fire scenarios, temperatures higher than 350°C or even 500°C can be attained within minutes, so a protective material is needed.

The amount of fire protection required to achieve this depends on a number of factors.

## Fire resistance of load-bearing steel constructions

The required fire resistance of the structure is indicated by the first number in the FRL. Eg. 120/-/- and is known as structural adequacy. This is often achieved by protecting with fire protective systems. The fire protective system shall be tested according to AS1530.4 or equivalent test standard by an accredited laboratory. The results of standardised tests are then used to create an assessment according to

AS4100. Dimensioning tables are part of the assessment, which list the necessary thickness of the fire protective material. Contractors must apply the appropriate thickness of the correct fire protective material according to the dimensioning tables. To determine the proper thickness of the material the following input data is required:

## Determine the material and configuration of the fire protection measures (boxed or profiled configuration)

Boxed configuration is typical for fire protective cladding. It provides reliable fire protection of load-bearing structures such as PROMATECT®-XS and simple installation. The thickness of the applied material is easy to check and the surface can be aesthetically finished.

## Fire resistance level (e.g. FRL 90/-/-)

The fire protection level of structure must be specified in the project. WARNING: Applicator who installs the fire protective material must have the basic information of the required characteristics for each case: fire resistance level and design temperature.

## Information about requested thermal stresses on the time / temperature curve (e.g. ISO 834)

In fire resistance tests, structures can be exposed to different time/temperature relations, known as fire curves. The most common one is the standard fire curve (also called ISO 834 or cellulosic fire curve) which is valid for most buildings. All information in this design guideline is valid for the standard fire curve. However other fire curves exist, such as the hydrocarbon (HC) fire

curve for petrochemical applications and the Rijkswaterstaat (RWS) and modified hydrocarbon (HCM) curves for tunnels. For such requirements, contact the local Promat office.

## Design temperature (e.g. 500°C)

The strength of steel reduces with increasing temperature. When heated under fire, the strength is reduced to a level where the loads can no longer be carried, and the structure will then fail. The higher the load on the steel element, the lower the failure temperature will be. This failure temperature is called the critical steel temperature. The critical steel temperature for each element is derived from the calculations set out in AS4100. This critical steel temperature serves as the design temperature for the determination of the fire protection thickness. A lower design temperature is more demanding and requires a higher thickness of protective material. The assessment provides thickness for design temperatures ranging from 350°C to 750°C. Where no critical temperature is provided default values of 550°C for columns and 620°C for beams could be considered as relatively conservative, however best practice would be to ensure the critical temperature is known.

### Details of all members of steel structures - section type, size, cross-sectional area, open / closed, exposure to fire.

The input data is the source for calculating section factor  $H_p/A$  or  $ESA/M$  for each member and determines the thickness of the fire protection.

The geometric shape of the steel section has a great influence on its behaviour under fire conditions. Sections are divided into two groups:

- Open sections - no cavities, such as sections I, H, L, T, U, C
- Hollow sections - RHS - Rectangular Hollow Sections, SHS - Square Hollow Sections and CHS - Circular Hollow Sections.

### Exposure to fire

Elements of steel structures are often exposed to fire from three or four sides. For example, if a steel beam is protected from the top by a concrete slab, it is exposed to the fire from three sides.

Some features are only partially exposed to fire, from 1 or 2 sides (assuming that the fire resistance of the element meets at least the required rating). The greater the surface exposed to fire, the faster the member heats. This physical dependence is taken into account when calculating the section factor  $H_p/A$  or  $ESA/M$ .

### Calculation of section factor $H_p/A$











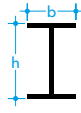





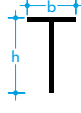



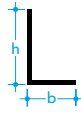

The degree of fire protection depends on the  $H_p/A$  section factor for the steel section. The  $H_p/A$  factor is a function of the length of the exposed perimeter of the steel exposed to the fire and the cross sectional area of the steel section. The higher the  $H_p/A$ , the faster the steel section heats up, and so the greater the thickness of fire protection material required. The section factor and critical temperature are the most important factors used to determine the thickness of protection required.

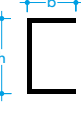

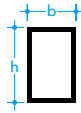

### Various box protection

Protection configurations with values of perimeter  $H_p$  for use in the calculation of section factor  $H_p/A$  ( $A/V$ )

Steel section	Box protection				
	Four sides	Three sides	Three sides (partially exposed)	Two sides	One side (partially exposed)
I & H sections 	 $2b + 2h$	 $b + 2h$	 $b + 2d$	 $b + h$	 $b$
T sections 	 $2b + 2h$	 $b + 2h$	 $b + 2h$		
L sections 	 $2b + 2h$	 $b + 2h$	 $b + 2h$		
U sections  $H_p$	 $2b + 2h$	 $2b + h$	 $b + 2h$		
Square or rectangular hollow sections 	 $2b + 2h$	 $2b + h$			
Circular hollow sections 	 $\pi D$	NOTE: The air space created in boxing a circular section improves the insulation. Therefore, $A_p$ higher than profile protection would be anomalous. Hence, the calculated $A_p$ per section length is taken as the circumference of the circular section ( $\pi D$ ) and not $4D$ .			

## Design tables

Table 1: Column Cladding at 550°C AS4100 (FAS230021) Noggins

Fire Resistance	Limiting Section Factor per thickness				
	15mm	20mm	25mm	30mm (15 + 15)	35mm (15 + 20)
30 mins	320	-	-	-	-
60 mins	210	320	-	-	-
90 mins	100	140	260	325	-
120 mins	-	-	-	190	325

Table 2: Beam Cladding at 620°C AS4100 (FAS230021) Noggins

Fire Resistance	Limiting Section Factor per thickness				
	15mm	20mm	25mm	30mm (15 + 15)	35mm (15 + 20)
30 mins	320	-	-	-	-
60 mins	290	320	-	-	-
90 mins	120	190	320	-	-
120 mins	-	-	-	325	-

**Note: For alternative critical limiting temperatures please contact Promat for specification of required thickness.**

**Table 3: PROMATECT®-XS thicknesses for onesteel structural steel members universal columns.**

Noggin Installation Method					
EXPOSURE CONDITIONS: I-Section Columns.					
Critical Temp: 550°C average.					
Four (4) sided exposure.					
Member	ESA/M ratio	PROMATECT®-XS thickness (mm) to provide fire resistance level of			
Universal Columns	(M <sup>2</sup> /T)	30 min	60 min	90 min	120 min
310UC158	8.1	15	15	15	15 + 15
310UC137	9.2	15	15	15	15 + 15
310UC118	10.5	15	15	15	15 + 15
310UC97	12.7	15	15	15	15 + 15
250UC89	11.5	15	15	15	15 + 15
250UC73	13.9	15	15	20	15 + 15
200UC60	13.9	15	15	20	15 + 15
200UC52	15.7	15	15	20	15 + 15
200UC46	17.6	15	15	20	15 + 15
152UC37	17.0	15	15	20	15 + 15
152UC30	20.7	15	15	25	15 + 15
152UC23	26.1	15	15	25	15 + 20
100UC15	26.5	15	15	25	15 + 20



**Table 4: PROMATECT®-XS thicknesses for onesteel structural steel members universal beams.**

**Noggin Installation Method**

EXPOSURE CONDITIONS: I-Section beam supporting lightweight or dense concrete slab.

Critical Temp: 620°C average.

Three (3) sided exposure.

Member	ESA/M ratio (M <sup>2</sup> /T)	PROMATECT®-XS thickness (mm) to provide fire resistance level of			
		30 min	60 min	90 min	120 min
61O UB 125	11.6	15	15	15	15 + 15
61O UB 113	12.8	15	15	15	15 + 15
61O UB 101	14.2	15	15	15	15 + 15
53O UB 92	13.8	15	15	15	15 + 15
53O UB 82	15.4	15	15	20	15 + 15
46O UB 82	13.5	15	15	15	15 + 15
46O UB 74	14.8	15	15	15	15 + 15
46O UB 67	16.4	15	15	20	15 + 15
41O UB 60	16.6	15	15	20	15 + 15
41O UB 54	18.3	15	15	20	15 + 15
36O UB 57	15.6	15	15	20	15 + 15
36O UB 51	17.4	15	15	20	15 + 15
36O UB 45	19.6	15	15	20	15 + 15
31O UB 46	16.9	15	15	20	15 + 15
31O UB 40	19.1	15	15	20	15 + 15
25O UB 37	17.7	15	15	20	15 + 15
25O UB 31	20.7	15	15	20	15 + 15
20O UB 30	18.4	15	15	20	15 + 15
20O UB 25	21.3	15	15	20	15 + 15
18O UB 22	20.2	15	15	20	15 + 15
18O UB 18	24.3	15	15	25	15 + 15
15O UB 18	21.4	15	15	20	15 + 15
15O UB 14	26.8	15	15	25	15 + 15

**Table 5: PROMATECT®-XS thicknesses for onesteel structural steel members square hollow sections**
**Noggin Installation Method**

EXPOSURE CONDITIONS: Four sided protection to hollow columns.

Critical Temp: 550°C average.

Four (4) sided exposure.

Member	ESA/M ratio (M <sup>2</sup> /T)	PROMATECT®-XS thickness (mm) to provide fire resistance level of			
		30 min	60 min	90 min	120 min
400 x 400 x 16 SHS	8.6	15	15	15	15 + 15
400 x 400 x 12.5 SHS	10.8	15	15	15	15 + 15
400 x 400 x 10 SHS	13.4	15	15	20	15 + 15
350 x 350 x 16 SHS	8.7	15	15	15	15 + 15
350 x 350 x 12 SHS	10.9	15	15	15	15 + 15
350 x 350 x 10.0 SHS	13.5	15	15	20	15 + 15
350 x 350 x 8.0 SHS	16.6	15	15	20	15 + 15
300 x 300 x 16 SHS	8.8	15	15	15	15 + 15
300 x 300 x 12.5 SHS	11.0	15	15	15	15 + 15
300 x 300 x 9.5 SHS	13.6	15	15	20	15 + 15
300 x 300 x 8.0 SHS	16.8	15	15	20	15 + 15
250x 250 x 16 SHS	9.0	15	15	15	15 + 15
250 x 250 x 12.5 SHS	11.2	15	15	15	15 + 15
250 x 250 x 10.0 SHS	13.8	15	15	20	15 + 15
250 x 250 x 9.0 SHS	15.2	15	15	20	15 + 15
250 x 250 x 8.0 SHS	16.9	15	15	20	15 + 15
250 x 250 x 6.0 SHS	22.2	15	15	25	15 + 15
200 x 200 x 16 SHS	9.4	15	15	15	15 + 15
200 x 200 x 12.5 SHS	11.5	15	15	15	15 + 15
200 x 200 x 10.0 SHS	14.0	15	15	20	15 + 15
200 x 200 x 9.0 SHS	15.4	15	15	20	15 + 15
200 x 200 x 8.0 SHS	17.2	15	15	20	15 + 15
200 x 200 x 6.0 SHS	22.5	15	15	25	15 + 15
200 x 200 x 5.0 SHS	26.7	15	15	25	15 + 20
150 x 150 x 10.0 SHS	14.5	15	15	20	15 + 15
150 x 150 x 9.0 SHS	15.9	15	15	20	15 + 15
150 x 150 x 8.0 SHS	17.7	15	15	20	15 + 15
150 x 150 x 6.0 SHS	22.9	15	15	25	15 + 15
150 x 150 x 5.0 SHS	27.2	15	20	25	15 + 20

Table 5: PROMATECT®-XS thicknesses for onesteel structural steel members square hollow sections

## Noggin Installation Method

EXPOSURE CONDITIONS: Four sided protection to hollow columns.

Critical Temp: 550°C average.

Four (4) sided exposure.

Member	ESA/M ratio (M <sup>2</sup> /T)	PROMATECT®-XS thickness (mm) to provide fire resistance level of			
		30 min	60 min	90 min	120 min
125 x 125 x 10 SHS	15.0	15	15	20	15 + 15
125 x 125 x 9 SHS	16.3	15	15	20	15 + 15
125 x 125 x 8 SHS	18.1	15	15	25	15 + 15
125 x 125 x 6 SHS	23.3	15	15	25	15 + 15
125 x 125 x 5 SHS	27.5	15	20	25	15 + 20
125 x 125 x 4 SHS	33.9	15	20	15 + 15	15 + 20
100 x 100 x 10.0 SHS	15.6	15	15	20	15 + 15
100 x 100 x 9.0 SHS	17.0	15	15	20	15 + 15
100 x 100 x 8.0 SHS	18.7	15	15	25	15 + 15
100 x 100 x 6.0 SHS	23.9	15	15	25	15 + 15
100 x 100 x 5.0 SHS	28.1	15	20	25	15 + 20
89 x 89 x 6.0 SHS	24.3	15	15	25	15 + 20
89 x 89 x 5.0 SHS	28.4	15	20	25	15 + 20
89 x 89 x 3.5 SHS	39.3	15	20	15 + 15	15 + 20
75 x 75 x 6.0 SHS	24.9	15	15	25	15 + 20
75 x 75 x 5.0 SHS	29.1	15	20	25	15 + 20
75 x 75 x 3.5 SHS	37.9	15	20	15 + 15	15 + 20
65 x 65 x 6.0 SHS	25.6	15	15	25	15 + 20
65 x 65 x 5.0 SHS	29.7	15	20	25	15 + 20
65 x 65 x 4.0 SHS	36.0	15	20	15 + 15	15 + 20
50 x 50 x 6.0 SHS	27.3	15	20	25	15 + 20
50 x 50 x 5.0 SHS	31.3	15	20	25	15 + 20
50 x 50 x 4.0 SHS	37.4	15	20	15 + 15	15 + 20
40 x 40 x 4.0 SHS	39.1	15	20	15 + 15	15 + 20



**Table 6: PROMATECT®-XS thicknesses for onesteel structural steel members rectangular hollow sections**

Noggin Installation Method					
EXPOSURE CONDITIONS: Four sided protection to hollow columns.					
Critical Temp: 550°C average.					
Four (4) sided exposure.					
Member	ESA/M ratio	PROMATECT®-XS thickness (mm) to provide fire resistance level of			
Rectangular Hollow Sections	(M <sup>2</sup> /T)	30 min	60 min	90 min	120 min
400 x 300 x 16 RHS	8.2	15	15	15	15 + 15
400 x 300 x 12.5 RHS	10.5	15	15	15	15 + 15
400 x 300 x 10 RHS	13.0	15	15	20	15 + 15
400 x 300 x 8 RHS	16.2	15	15	20	15 + 15
400 x 200 x 16 RHS	8.3	15	15	15	15 + 15
400 x 200 x 12.5 RHS	10.6	15	15	15	15 + 15
400 x 200 x 10 RHS	13.1	15	15	20	15 + 15
400 x 200 x 8 RHS	16.3	15	15	20	15 + 15
350 x 250 x 16 RHS	8.3	15	15	15	15 + 15
350 x 250 x 12.5 RHS	10.6	15	15	15	15 + 15
350 x 250 x 10 RHS	13.1	15	15	20	15 + 15
350 x 250 x 8 RHS	16.3	15	15	20	15 + 15
300 x 200 x 16 RHS	8.4	15	15	15	15 + 15
300 x 200 x 12.5 RHS	10.6	15	15	15	15 + 15
300 x 200 x 10 RHS	13.2	15	15	20	15 + 15
300 x 200 x 8 RHS	16.3	15	15	20	15 + 15
300 x 200 x 6 RHS	21.7	15	15	25	15 + 15
250 x 150 x 16 RHS	8.6	15	15	15	15 + 15
250 x 150 x 12.5 RHS	10.8	15	15	15	15 + 15
250 x 150 x 10 RHS	13.3	15	15	20	15 + 15
250 x 150 x 9 RHS	14.7	15	15	20	15 + 15
250 x 150 x 8 RHS	16.5	15	15	20	15 + 15
250 x 150 x 6 RHS	21.8	15	15	25	15 + 15
250 x 150 x 5 RHS	26.0	15	15	25	15 + 20

**Table 6: PROMATECT®-XS thicknesses for onesteel structural steel members rectangular hollow sections**

**Noggin Installation Method**

EXPOSURE CONDITIONS: Four sided protection to hollow columns.

Critical Temp: 550°C average.

Four (4) sided exposure.

Member	ESA/M ratio (M <sup>2</sup> /T)	PROMATECT®-XS thickness (mm) to provide fire resistance level of			
		30 min	60 min	90 min	120 min
200 x 100 x 10 RHS	13.5	15	15	20	15 + 15
200 x 100 x 9 RHS	14.9	15	15	20	15 + 15
200 x 100 x 8 RHS	16.7	15	15	20	15 + 15
200 x 100 x 6 RHS	22.0	15	15	25	15 + 15
200 x 100 x 5 RHS	26.2	15	15	25	15 + 20
152 x 76 x 6 RHS	22.2	15	15	25	15 + 15
152 x 76 x 5 RHS	26.4	15	15	25	15 + 20
150 x 100 x 10 RHS	13.7	15	15	20	15 + 15
150 x 100 x 9 RHS	15.1	15	15	20	15 + 15
150 x 100 x 8 RHS	16.8	15	15	20	15 + 15
150 x 100 x 6 RHS	22.1	15	15	25	15 + 15
150 x 100 x 5 RHS	26.3	15	15	25	15 + 20
150 x 50 x 6 RHS	22.4	15	15	25	15 + 15
150 x 50 x 5 RHS	26.6	15	15	25	15 + 20
127 x 51 x 6 RHS	22.5	15	15	25	15 + 15
127 x 51 x 5 RHS	26.7	15	15	25	15 + 20
125 x 75 x 6 RHS	22.4	15	15	25	15 + 15
125 x 75 x 5 RHS	26.6	15	15	25	15 + 20
102 x 76 x 6 RHS	22.5	15	15	25	15 + 15
102 x 76 x 5 RHS	26.7	15	15	25	15 + 20
100 x 50 x 6 RHS	22.8	15	15	25	15 + 15
100 x 50 x 5 RHS	27.0	15	20	25	15 + 20
75 x 50 x 6 RHS	23.2	15	15	25	15 + 15
75 x 50 x 5 RHS	27.4	15	20	25	15 + 20

# General processing instructions, handling, cutting and fixing

- The boards are delivered on pallets.
- The boards shall be horizontally stacked on a flat surface in a dry and ventilated space.
- The boards shall always be manipulated from the stack by two persons and then be transported vertically.

## Choice of thickness

- The required thickness of the fire protective cladding depends on the required fire resistance, the design temperature of the steel structure (the maximum allowed critical temperature of the steel member) and the Hp/A or Esa/M ratio. Please refer to the tables earlier in this manual to determine the required thickness of PROMATECT®-XS.
- Increasing the thickness of the cladding is allowed from the fire safety point of view.
- The thinner board should always be mounted on the thicker board.

## Cutting

- Easy cutting using a knife (score & snap technique).
- **Power tools with dust extraction equipment:**  
Sawing machines such as FESTOOL, Bosch, Makita etc work with a tungsten carbide tipped saw blade on a low speed electric motor and move over a fixed working table. It is a typical machine for occasional use on site producing very good results and is capable of cutting boards with maximum thickness up to 25mm. A vacuum cleaner is recommended for use while cutting especially when using power saws. As an additional safety precaution, always wear eye, ear and dust protection when using power tools of any type. A portable version of the working table is available for the convenience of board cutting on site.

While working with power saws, the following important points should be observed:

- Ensure that the boards to be cut are continuously and well supported on either side of the cut.
- A straight edge should be clamped in position to guide the cutting operation.
- Care must be taken to ensure the tool remains against the straight edge during the cutting operation.
- The cutting rate should be such that the blade is not labouring or over-heating. Feed speed for fibre cement boards is normally slower than for natural timber.

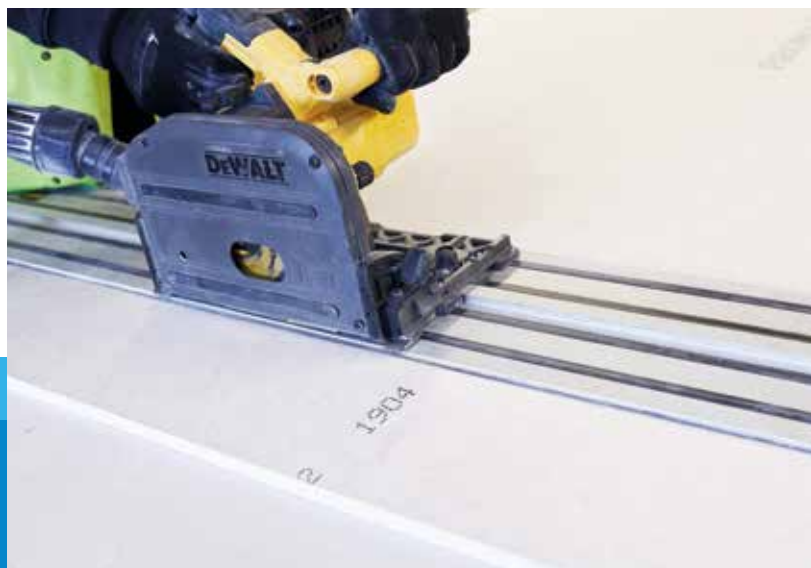



### Plastering / Finishing

PROMATECT®-XS is not required to be set and finished to achieve fire resistance. But should the project require a given aesthetic finish, then the application of standard plasterboard beads and topping compounds can be applied.

The preferred and best quality finishing method for PROMATECT®-XS protected steel members is to set and finish as you would with plasterboard systems.

External beads should be placed on each corner then a standard of the shelf bedding and setting system suitable for plasterboard be applied in accordance with the manufacturer's recommendations.

If a plaster skim coat is required, apply a sealing coat of diluted universal primer/PVA (e.g. 1 part PVA and 5 parts water). Sealing coat should be allowed to dry thoroughly (approximately 24 hours). Apply bonding coat (3 parts PVA and 1 part water).

Apply plaster skim (3mm thick) while the bonding coat is wet and tacky

### Tiling

PROMATECT® XS boards can be tiled, provided due consideration is given to the installation of the boards and the requirements for additional framing prior to applying the tiles.

It should be noted that PROMATECT®-XS board application systems are used for their fire resistance performance.

Therefore placing additional weight on an application system, such as ceramic or marble tiling for instance, can have significant effect on the overall fire resistance performance of the system.

As such, additional framing is required for partition systems etc which bear the weight of tiles in order to maintain the fire resistance performance.

Care must be taken in sealing the boards thoroughly before applying any tile adhesive as the boards' high suction load will accelerate the setting time of the tile adhesive.

### Painting

All coatings should be supplied by a reputable manufacturer and their recommendations regarding surface preparation, sealing and finish coating should be followed at all times.

When using water based paints, a diluted first coat is recommended. For oil based paints a suitable alkali resisting primer should be used.

Painted vapour barriers may be formed by the application of chlorinated rubber, epoxy resin or polyurethane paint.

The smooth surface of PROMATECT®-XS boards can be painted with emulsion or oil based paints after applying with a universal primer. With water based paints, a diluted first coat should be applied.



# Protection of columns

## General

- Cladding of steel column is generally done from four sides.
- Board joints on different faces should be offset by minimum 500mm.
- Board joints and fixing heads do not require sealing or covering.
- Where the joint between the bottom of the board and the floor exceeds 3mm then it should be filled with PROMASEAL®-A Acrylic Sealant.



## Installation of single layer of PROMATECT®-XS for columns

- Cut noggins 120mm wide from the PROMATECT®-XS board. The noggin should be sized such that it can be wedged between the flanges of the column. Once the noggin is cut, cut it at an angle of approximately 15° starting at a point one third of the way from the top. This will create two wedges. These are installed so that the 120mm width is parallel to the column web and are flush with the flange tips. Place the two parts together and hammer to wedge them in place. Noggins are required at maximum 1200mm centres.
- Noggins are not required for hollow sections such as SHS and RHS tables for further details.
- The board that is hard against the flanges of the column shall be cut at the same width as the flange. Where the board is hard against the steel, no joint cover or noggin is required. The boards on the noggin/web faces shall be cut to overlap the board fixed to the flange peices.
- Fix the boards through the face of the web board into the edge of the flange board at maximum 100mm centres with staples. (Refer table for size & length). Web Boards are also stapled to the noggins at 100mm centres.
- No joint filler is needed.

## Installation of double layer of PROMATECT®-XS for columns

- Board joints on different layers should be offset by minimum 600mm.
- Cut and install noggins as per the single layer system with the noggins installed in line with the joints of the first layer of board at maximum 1200mm centres.
- Noggins are not required for hollow sections such as SHS and RHS.
- First layer of board installed in the same manner as the single layer construction. The second layer is installed in a similar manner with the board on the flange side installed between the boards on the web side.
- Fix the boards through the face of the web board into the edge of the flange board at maximum 100mm centres with staples. (Refer table for size & length). Where board joints occur in the second layer, they should be stapled on each side of the joint to the first layer at 100mm centres.
- No joint filler is needed.

SINGLE LAYER PROTECTION

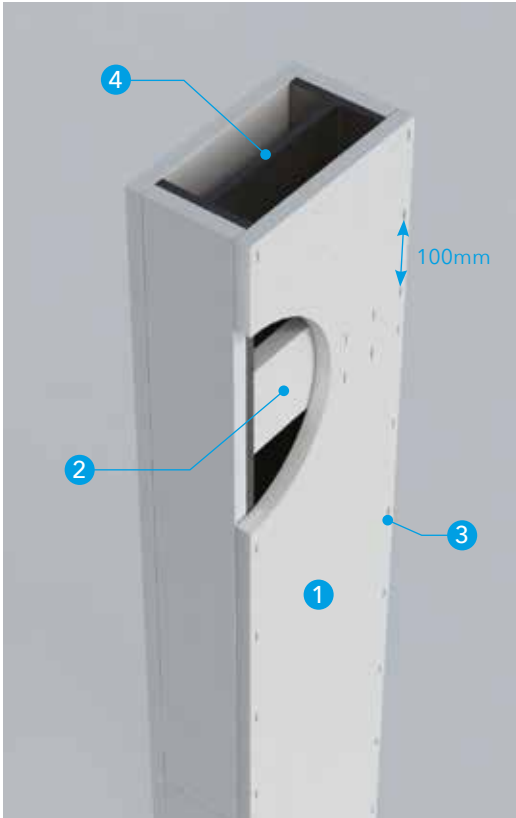

DOUBLE LAYER PROTECTION

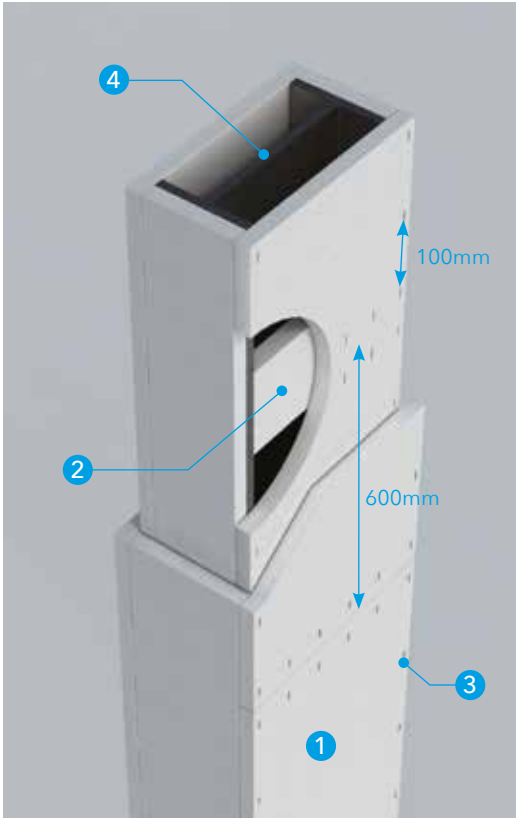

- 1 PROMATECT®-XS
- 2 Wedge noggin at max. 1200mm centres
- 3 Staple
- 4 Steel member



Example of noggin construction



Protection of hollow sections

# Protection of beams

## General

- Cladding of steel beams is generally done from three sides.
- PROMATECT®-XS noggin shall be adjusted in such a way that their outer noggin surfaces protrude about 5mm over the support flange. The cladding shall be fastened to the noggin. The drawings show the standard detail for three-sided cladding of steel beams. The required data for Hp/A value calculation and determination of the required thickness of cladding are given in the tables earlier in this manual.



## Installation of single layer of PROMATECT®-XS for beams

- Cut noggins 120mm wide from the PROMATECT®-XS board. The noggin should be sized such that it can be wedged between the flanges of the column. Once the noggin is cut, cut it at an angle of approximately 15° starting at a point one third of the way from the top. This will create two wedges. These are installed so that the 120mm width is parallel to the column web and are protruding approximately 5mm from the flange tips. Place the two parts together and hammer to wedge them in place. Noggins are required at maximum 1200mm centres.
- The underside board is installed in between the 2 side boards, and does not require a noggin or coverstrip where board joints occur. Joints between the underside and side boards should be offset by 500mm.
- Install the side boards first by fixing to the noggins with staples at 100mm centres. The underside board is then fitted between the side ones and fixed with staples at 100mm centres also. For staple specification refer to the table on the right.
- No joint filler is needed.

## Installation of double layer of PROMATECT®-XS for beams

- The first layer is installed in the same manner as the single layer construction except that the board joints on the flange and web side are not required to be staggered.
- Board joints for the second layer should be staggered by 600mm from joints in the first layer.
- The second layer is installed in the same manner as the first with the underside board fitted between the two side boards and stapled board to board at 100mm centres. There is no requirement to stagger the joints between the underside and side of the second layer.
- Where board joints occur in the underside or side boards they should be fixed to the first layer with staples at 100mm centres on each side of the joint.
- No joint filler is needed.



SINGLE LAYER PROTECTION

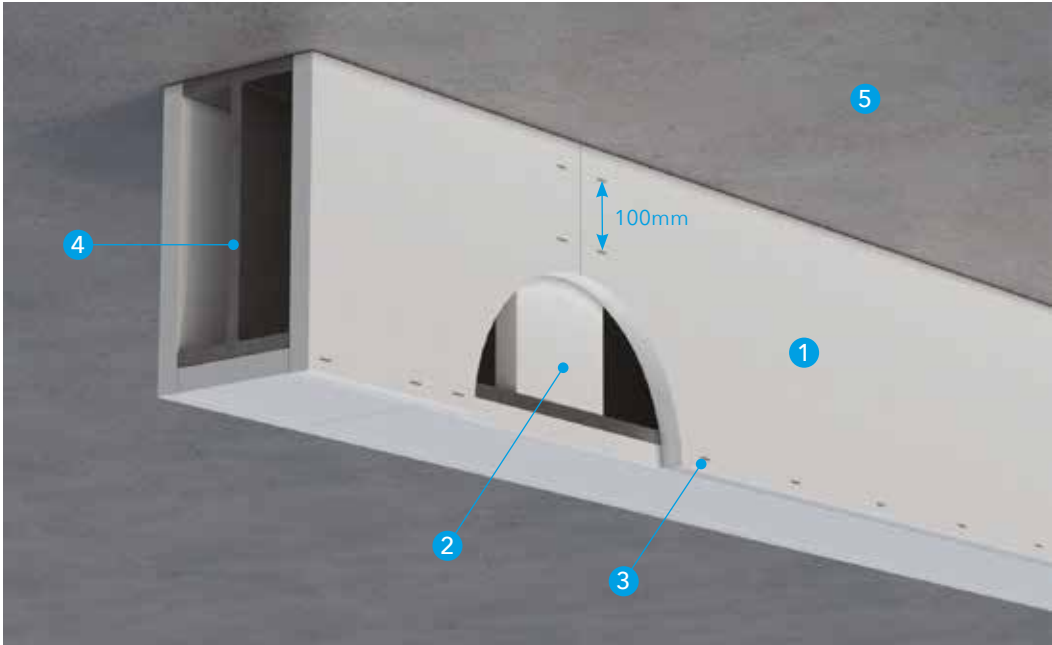

DOUBLE LAYER PROTECTION

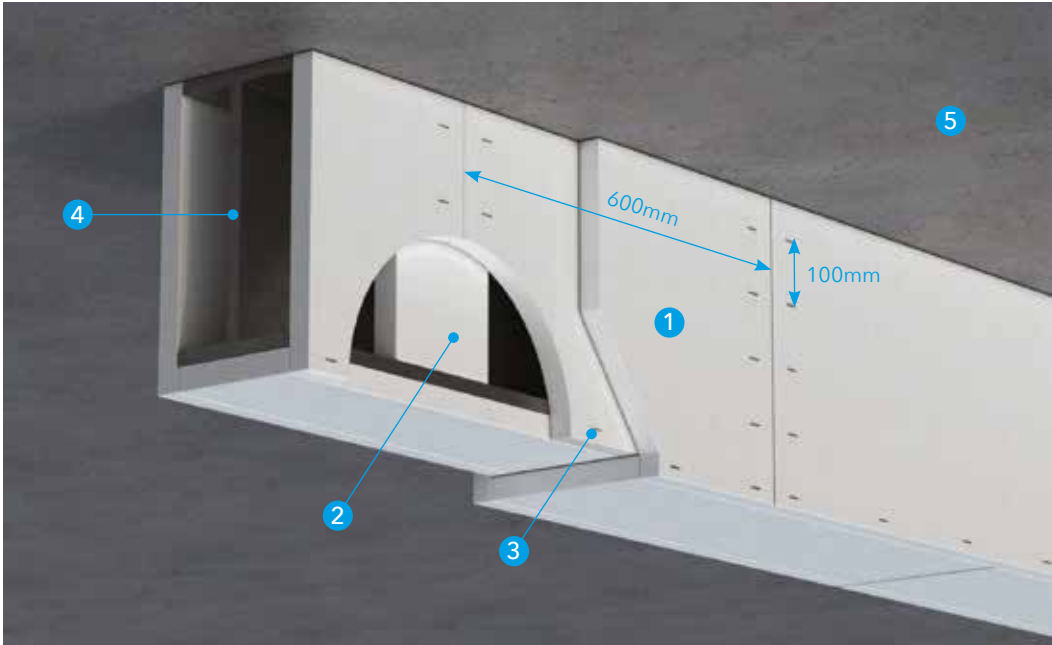

- 1 PROMATECT®-XS
- 2 Wedge noggin at max. 1200mm centres
- 3 Staple
- 4 Steel member
- 5 Concrete slab

## STAPLE LENGTH FOR BOARD THICKNESS:

### Single and double layer cladding:

Type	Staples
Material	Steel
Dimensions	
for 15mm thick boards	Length 35mm, bridge 10.5mm, wire 1.45 x 1.30mm
for 20mm thick boards	Length 40mm, bridge 10.5mm, wire 1.45 x 1.30mm
for 25mm thick boards	Length 50mm, bridge 10.5mm, wire 1.45 x 1.30mm

### Providing fire protection of steel structures at the construction site

- The required fire resistance is achieved only after proper and professional installation of the product.
- The Installer must follow all requirements of the installation process to ensure that an approved system is installed.
- The installer should ensure that the system is suitable for the specific conditions in which it is to be installed.

### Connection to other systems and unprotected members

- Refer to NCC Clause 1.8/ C2D9 Lightweight Construction to determine if voids behind the protection will require filling to meet indentation and damage requirements.
- Where the PROMATECT®-XS interfaces with an unprotected member a coatback of 300mm length will be required. The thickness will be as per the protected member.
- Where the PROMATECT®-XS Interfaces with a Cafco Spray system the spray shall overlap onto the board by a minimum 100mm.



Interface drawing



Coatback drawing

# Technical Characteristics

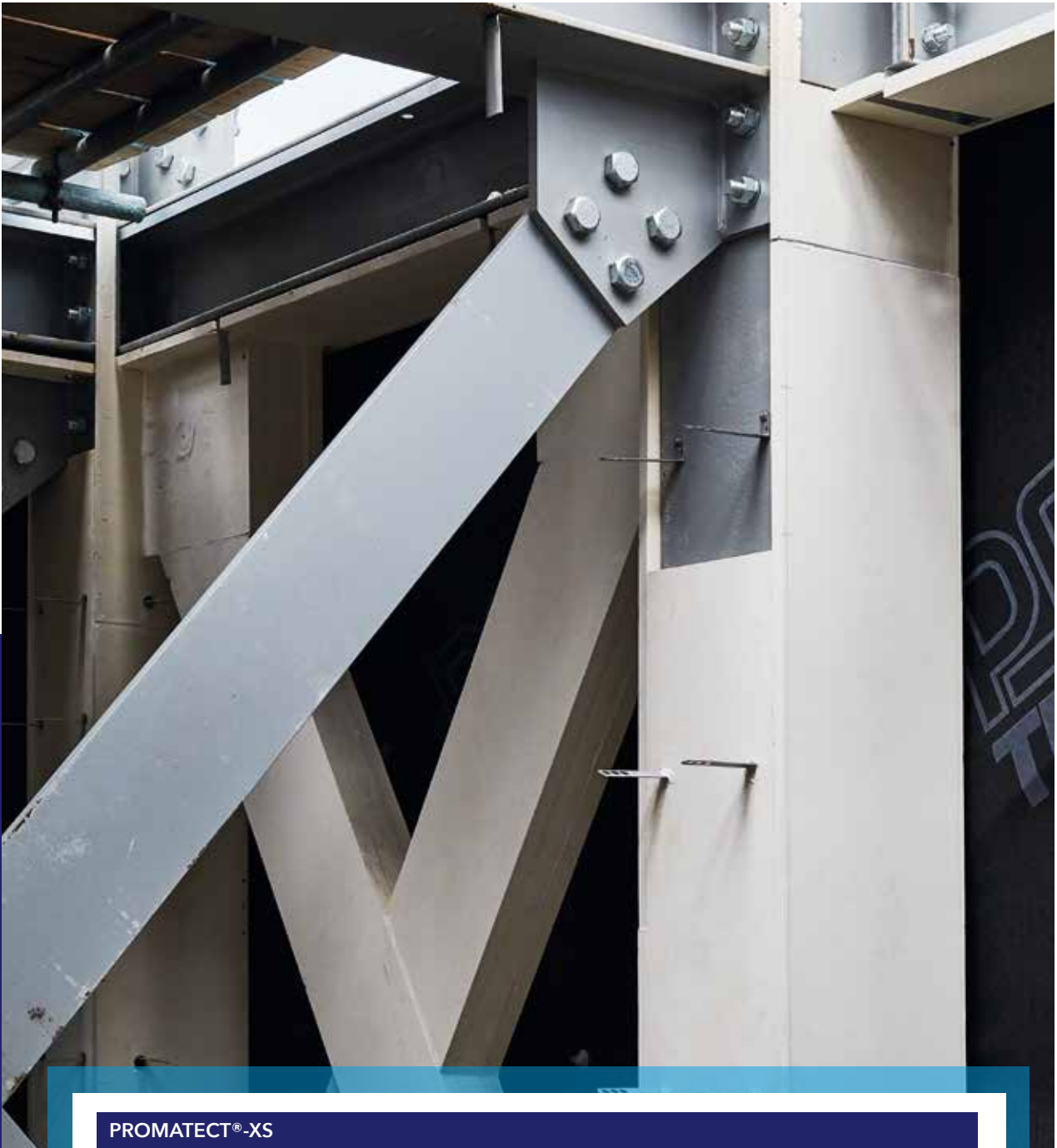

## PROMATECT®-XS

Product Code	Thickness (mm)	Length (mm)	Width (mm)	Boards/pallet	Nominal weight (kg/m <sup>2</sup> )
299044	15	2500	1200	32	13.7
299045	20	2500	1200	24	18.3
299046	25	2000	1200	24	22.9













## Our technical support for your next project

**We understand that designing and building a passive fire protection solution is often not an easy task.**

We can help you to interpret your local regulations and assess the risks in your building project that demand a reliable fire safety solution.

We can provide you with a full technical report and all the supporting documents you need to finalise your design and start the building process.

We offer you technical support and practical advice to deliver a perfect fire safety job.

**Do not hesitate to contact us.**

 [PAPL.mail@etexgroup.com](mailto:PAPL.mail@etexgroup.com)

 1800 Promat (776 628)



## Promat Australia Pty Ltd

### South Australia office

1 Scotland Road  
SA 5031 Mile End South  
☎ 1800 Promat (776 628)  
☎ +61 8 8352 1014  
✉ PAPL.mail@etexgroup.com

### New South Wales office

Unit 1, 175 Briens Road  
Northmead, NSW 2152  
☎ 1800 Promat (776 628)  
☎ +61 2 9630 0258  
✉ PAPL.mail@etexgroup.com

### Victoria office

Unit 1, 355 Grieve Parade  
Altona North, VIC 3025  
☎ 1800 Promat (776 628)  
☎ 1800 334 598  
✉ PAPL.mail@etexgroup.com

### Queensland office

80 Stradbroke St  
Heathwood QLD 4110  
☎ 1800 011 376  
☎ 1800 334 598  
✉ PAPL.mail@etexgroup.com

[promat.com](http://promat.com)