



RELN Septic and Holding Tanks

- 15 year warranty
- Australian Standards Approved AS/NZS1546:1:2008 On-site domestic wastewater treatment units – Septic Tanks Lic
- Unique stepped ribs for greater strength
- Lid and Manhole cover UV protected
- Lightweight and suitable for easy and cost effective transport



AS/NZS 1546.1 AM1651

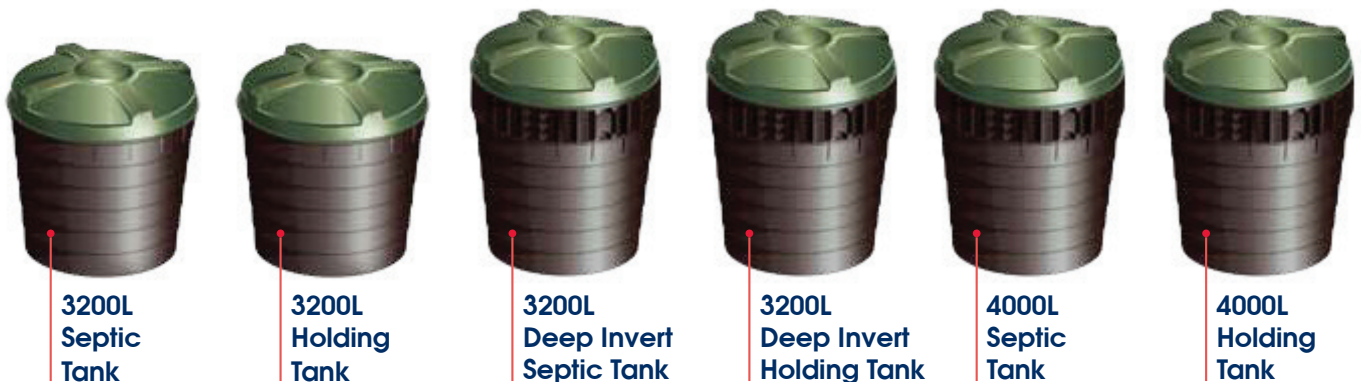

3200L Septic Tank

3200L Holding Tank

3200L Deep Invert Septic Tank

3200L Deep Invert Holding Tank

4000L Septic Tank

4000L Holding Tank

F Foundation L Landscape Y Yard

Septic and Holding Tanks

RELN's complete range of purpose designed blackwater tanks take quality, safety and convenience to the next level. The range is Australian Standards Approved and comes with a 15 year warranty.

> 3200L Septic Tank (2038 height x 1998mm diameter)

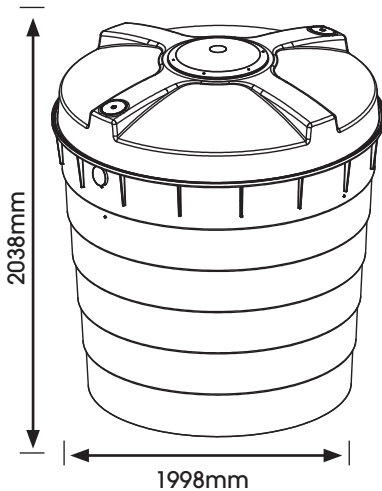

- Ideal for three to four bedroom homes
 - Australian Standards Approved - AS/NZS1546.1:2008 On-site domestic wastewater treatment units –Septic tanks Lic AMI1651
 - Easy to Transport 122kg base, 139kg with baffle
 - Lightweight and easy to manage without a crane.
 - Riser kits packed and stored inside tank for delivery
 - Can be stacked for cost effective transport
 - Unique stepped ribbing for added strength
 - UV protected green lid reduces effect of sunlight
 - Built in locking alignment prevents incorrect fitting of lid to base
 - Septic Tanks are supplied as a complete kit including inlet and outlet T-Junctions
 - 15 Year Warranty
- Range:** Fully Moulded Baffle, Standard Septic Tank Installation Kit, Riser Kit
- Display:** Brochure Available

> 3200L Holding Tank (2038 height x 1998mm diameter)

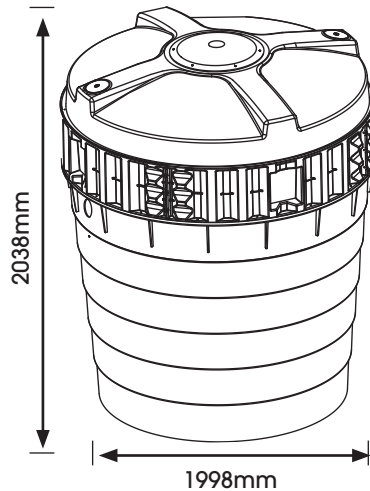

- Ideal for holding excess effluent from Septic Tanks
 - Waste pumped out by effluent tanker
 - Australian Standards Approved - AS/NZS1546.1:2008 On-site domestic wastewater treatment units –Septic tanks Lic AMI1651
 - Easy to Transport 122kg base, 139kg with baffle
 - Lightweight and easy to manage without a crane
 - Riser kits packed and stored inside tank for delivery
 - Can be stacked for cost effective transport
 - Unique stepped ribbing for added strength
 - UV protected grey lid reduces effect of sunlight
 - Built in locking alignment prevents incorrect fitting of lid to base
 - Septic Tanks supplied as a complete kit including inlet and outlet T-Junctions
 - 15 Year Warranty
- Range:** Standard Septic Tank Installation Kit
- Display:** Brochure Available

> 4000L Septic Tank (2410 height x 1998mm diameter)

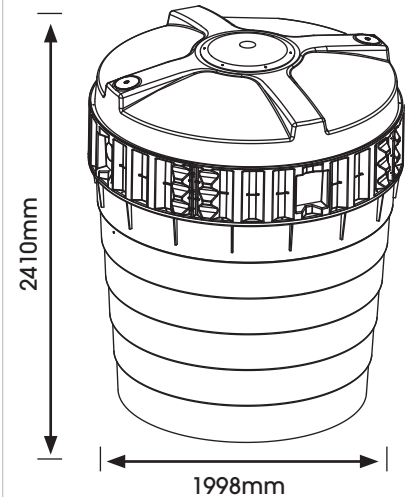

- Ideal for four to five bedroom homes
 - Australian Standards Approved - AS/NZS1546.1:2008 On-site domestic wastewater treatment units –Septic tanks Lic AMI1651
 - Easy to Transport 159kg base, 181kg with baffle
 - Lightweight and easy to manage without a crane
 - Unique stepped ribbing for added strength
 - Reinforced polypropylene structural brace ring prevents crushing when installed deep in the ground
 - Built in locking alignment prevents incorrect fitting of lid to base
 - Septic Tanks are supplied as a complete kit including inlet and outlet T-Junctions
 - 15 Year Warranty
- Range:** Fully Moulded Baffle, Standard Septic Tank Installation Kit
- Display:** Brochure Available

> Frequently Asked Questions

Q1. Can I get a riser for the 4000L Tank?

A. No.

Q2. How big a tank do I need for my home?

A. Please check with your local council body for septic requirements.

Q3. Can I get replacement parts?

A. Yes. RELN supplies a 15 year warranty under the AS/NZS 1546. 1:2008 Standard Lic AMI1651

➤ **4000L Holding Tank**
(2410 height x 1998mm diameter)

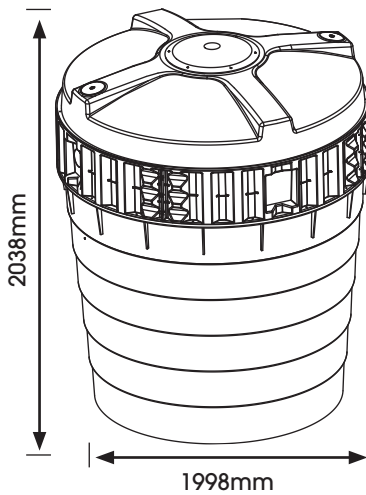

- Ideal for holding excess effluent from Septic Tanks
- Waste is pumped out by effluent tanker
- Australian Standards Approved - AS/NZS1546.1:2008 On-site domestic wastewater treatment units –Septic tanks Lic AM11651
- Easy to Transport 159kg base, 181 with baffle
- Lightweight and easy to manage without a crane
- Unique stepped ribbing for added strength
- To be maintained at 50% capacity to prevent floatation
- Stores effluent for pump out by effluent tanker
- UV protected grey lid reduces effect of sunlight
- Built in locking alignment prevents incorrect fitting of lid to base
- Septic Tanks supplied as a complete kit including inlet and outlet T-Junctions
- 15 Year Warranty

Range: Fully Moulded Baffle, Standard Septic Tank Installation Kit

Display: Brochure Available



RELN
>blackwater



3200L Septic Tank

Product Code	Description	Weight (kg)	Barcode
000780S	Septic Tank - 3200L Standard Pack - No Baffle, Drilled base, Lid, Manhole and Accessory	N/A	9 319022 007807
000780C	Septic Tank - 3200L complete with Drilled base, Lid, Manhole, Accessory and Injected Moulded Baffle	140kg	9 319022 007814
000992	Septic Tank - 3200L Drilled Base Only	94.5kg	9 319022 009924
000709	Septic Tank - 3700L No Drill Holes - Base Only	94.5kg	9 319022 007098

RELN
>blackwater





3200L Holding Tank

Product Code	Description	Weight (kg)	Barcode
000791	Holding Tank - 3200L Undrilled Base, Lid, Manhole and Accessory Pack	N/A	9 319022 007913
000790	Holding Tank - 3200L Undrilled Base, Lid, Manhole, Accessory Pack with no outlet	N/A	9 319022 007906
000802	Holding Tank - 3200L complete with Reinforcing Ring Only - Drilled	96.7kg	9 319022 008026
000801	Holding Tank - 3200L, No Holes, Undrilled base complete with Reinforcing Ring, inspection Box, Lid and Manhole Cover	140kg	9 319022 008019



3200L Septic Tank With Riser

Product Code	Description	Weight (kg)	Barcode
000845	3200L Deep Invert Septic Tank, Undrilled Base complete with Reinforcing Ring, Riser, Lid, Accessory Pack, Manhole Cover and Lid	N/A	 9 319022 008453
000844	3200L Deep Invert Septic Tank, Undrilled Base complete with Reinforcing Ring, riser, lid, Manhole Cover, Accessory Pack, Lid and Baffle.	190kg	 9 319022 008446



3200L Holding Tank with Riser

Product Code	Description	Weight (kg)	Barcode
000846	3200L Deep Invert Holding Tank, Undrilled Base complete with Reinforcing Ring, Riser, Lid, Accessory Pack no outlet, Manhole Cover and Lid.	4.5kg	 9 319022 008460



4000L Septic Tank

Product Code	Description	Weight (kg)	Barcode
000841	Septic Tank - 4000L Standard without Baffle, Undrilled Base, Reinforcing Ring, Riser, Lid and Accessory Pack	N/A	 9 319022 008415
000840	Septic Tank - 4000L complete Undrilled Base, Reinforcing Ring, Riser, Lid, Accessory Pack and Injected Moulded Baffle	190kg	 9 319022 008408



4000L Holding Tank

Product Code	Description	Weight (kg)	Barcode
000842	Septic Tank - 4000L Holding Tank Complete, No Holes, Drill Base, Reinforcing Ring, Riser, Manhole, Lid, Accessory Pack and no Out Let	170kg	 9 319022 008422

Septic Tank - 3200L Green Lid Only

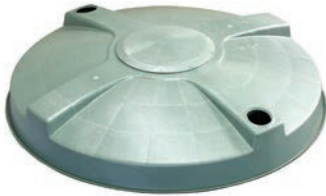

Product Code: 000994

Weight: 37kg

Diameter: 1940kg



9 319022 009948

Septic Tank - 3200L Baffle

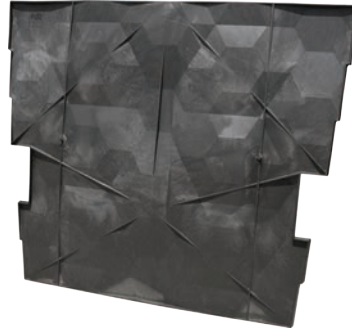

Product Code: 000988

Weight: 17kg



9 319022 009887

Septic Tank - 3200L Accessory Pack



Product Code: 000655

Weight: 2.2kg



9 319022 006558

Septic Tank - Manhole Cover - Green



Product Code: 000662

Weight: 2.8kg



9 319022 006626

Septic Tank - Inspection Box Lid Only - Green



Product Code: 000983

Weight: 0.2kg



9 319022 009832

Septic Tank - Inlet T Junction



Product Code: 000996

Weight: N/A



9 319022 009962

Septic Tank - Outlet T Junction



Product Code: 000998

Weight: 0.7kg



9 319022 009986

Septic Tank - Induct Vent Complete



Product Code: 000990

Weight: 0.3kg



9 319022 009900

**Septic Tank -
Outlet Junction Filter**

Product Code: 000997

Weight: 0.5kg

Features & Benefits:

Prolong the life of your trench by filtering your water.

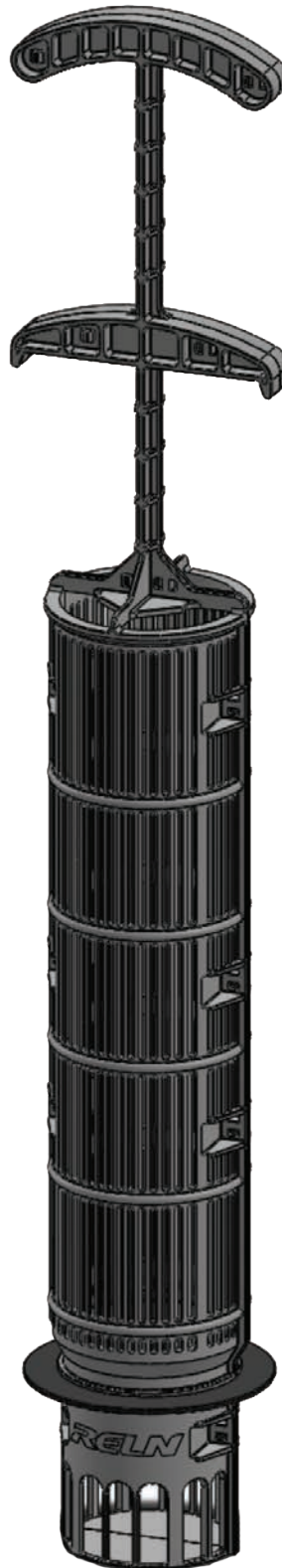
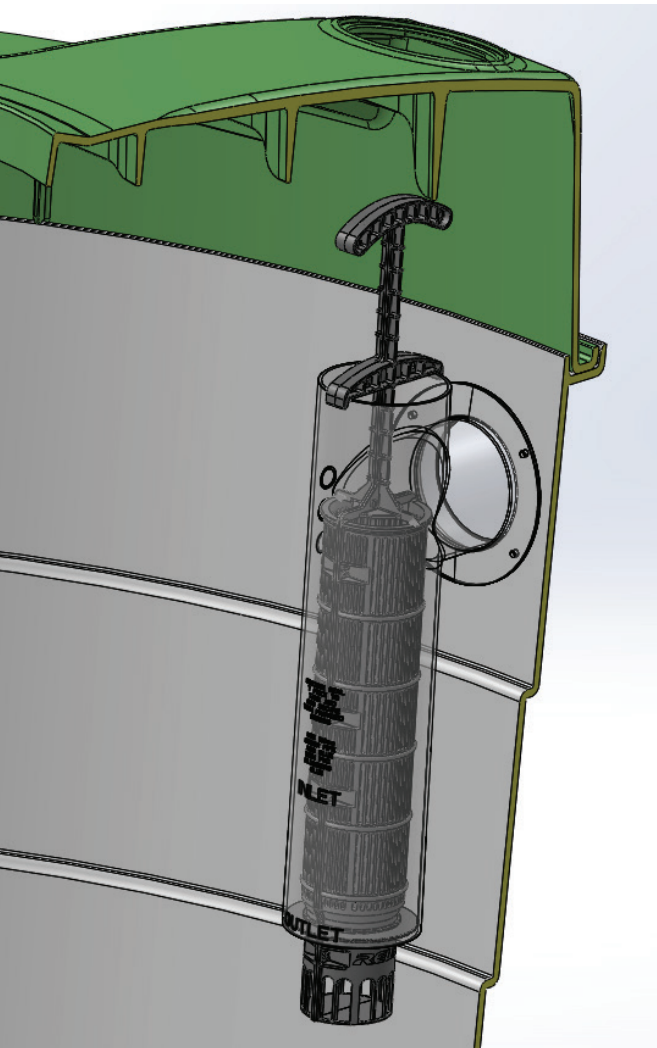

ISO TYPE 5

CERTIFICATE OF CONFORMITY



ApprovalMark International hereby grants:

RELN PTY LTD

14B Williamson Road
Ingleburn, NSW 2565
AUSTRALIA

ISO Type 5 Certificate of Conformity

Evaluated to:

AS/NZS 1546.1:2008 – On-site domestic wastewater treatment units – Septic Tanks

The ISO Type 5 License shall comply with all the terms and conditions as stipulated by the governance of the operating rules of the ISO Type 5 Scheme and shall comply with the standard requirements at all times including when the standard is amended. The ISO Type 5 License only covers the product which is identified in the attached product schedule.

Certificate No. AMI 1651

Issued: 7th July 2022

Current Certification: 7th July 2022

Expires: 7th July 2025

A handwritten signature in black ink, appearing to read "John Prasad".

John PRASAD

Director

ApprovalMark International Pty Ltd
18/33 Holbeche Road, Arndell Park 2148, Australia

www.approvalmark.com



Registered by: ApprovalMark International Pty Ltd (ABN 69 143 259 974) Unit 18, 33 Holbeche Road, Arndell Park NSW 2148 Australia. The assessment was carried with appropriate skill and assessment by ApprovalMark International Pty Ltd, however it will only accept its responsibility for proven negligence. The certificate remains the property of ApprovalMark International Pty Ltd.

ApprovalMark™

Approvals:

RELN Standard Mark Licence
NSW Approval
NT Approval
QLD Approval
SA Approval
TAS Approval
VIC Approval
WA Approval

Septic Care:

NSW Dept Local Govt (The Easy Septic Guide)
WA Department of Health (Understanding Septic Tank Systems)
VIC EPA (Installing Operating and Maintaining Septic Tanks) TAS
(Septic Tank Systems)
SA Health (Maintenance of Septic Tank Systems)