

# Uni-Pier Technical Manual

2023



[www.unipier.com.au](http://www.unipier.com.au)



**Product Selection Guide**

Uni-Piers are a smart but simple piercing/stumping system and designed to replace brick piers, concrete or timber stumps that in the past have been traditionally used as sub-floor supports.

Uni-Piers are a two part system each being prefabricated units comprising:-

- a "Assembly" (refer Head Types) available with or without ant cap and a structural flange for securing either timber or steel bearers or beams, and
- a square tubular steel (SHS) post to which is welded a base plate that is anchored to the concrete footing or pad. Can also be cast into the concrete footing.

The final stage of the manufacturing process is hot dip galvanising of the units for life-long durability making them suitable to be used in coastal environments with a 25 Year Guarantee. (refer website for details).

When assembled, the piers/stumps are adjustable to the desired height, so eliminating inaccuracies that are often evident in concrete footings or pads.

Once positioned and the height determined, the Uni-Pier head assembly and post are normally secured with a number of Metal TEK Screws or 14-20x22 or Series 500 to AS 3566 Class 4 self drilling and tapping screws in accordance with the design requirement (refer technical drawings/details on website).

Uni-Piers are non-combustible and will not rot, warp, shrink or harbour termites.

Uni-Piers are designed to suit any normal residential floor design loads and are able to support most roof and wall loads in all wind areas and are suitable for up to 5m fall in terrain or more with additional Structural Engineering BCA.

Uni-Piers comply with NCC and relevant Australian Standards.

**To Determine the Pier Height**

Uni-Piers are supplied in incremental lengths of 200mm or can be manufactured to specified lengths.

For Builders Grade piers (65 x 65) the length range is 200mm to 4000mm.

For Heavy duty piers (75 x 75) the length range is 200mm to 5000mm.

For Mega Grade piers (89 x 89) the length range is 200mm to 5000mm. Also available in 100mm x 100mm.

See website for all sizes.

**Base Plate to Top of Footing Detail**

To determine the height of the piers required; establish the distance from the top of each footing to the underside of each bearer then select the post to the nearest 200mm BELOW the dimension.

**Example**

Measured height – 675mm = 600mm Uni-Pier Post  
 Measured height – 725mm = 600mm Uni-Pier Post  
 Measured height – 1730mm = 1600mm Uni-Pier Post

**Base Plate Cast into Footing Detail**

To determine the height of Uni Piers required in this application, the depth of footing needs to be taken into account, allowing a MINIMUM of 150mm cover UNDERNEATH the bottom of the Uni-Pier baseplate. Actual embedment of the pier into concrete should be a MINIMUM of 300mm or to Structural Engineers design. Refer technical drawings and 25 Year Warranty for protective coating on website.

Such footings must be designed by a suitably qualified Structural Engineer.

**Steps for Selecting Piers**

- 1 Determine wind classification from Wind Region Map of Australia on page 3. Use recommended wind classification provided by a registered engineer.
- 2 Refer to Wind Classification System Table on page 3.
- 3 Determine pier height (as described) and bracing requirement on pages 6 and 7.  
 Note: Bracing may not be required where the base of a building is built with masonry walls.
- 4 Always consult your Structural Engineer.
- 5 For details of fixing head assemblies to posts and securing posts to footings, refer to technical drawings on website.

**Wind Region Map of Australia**

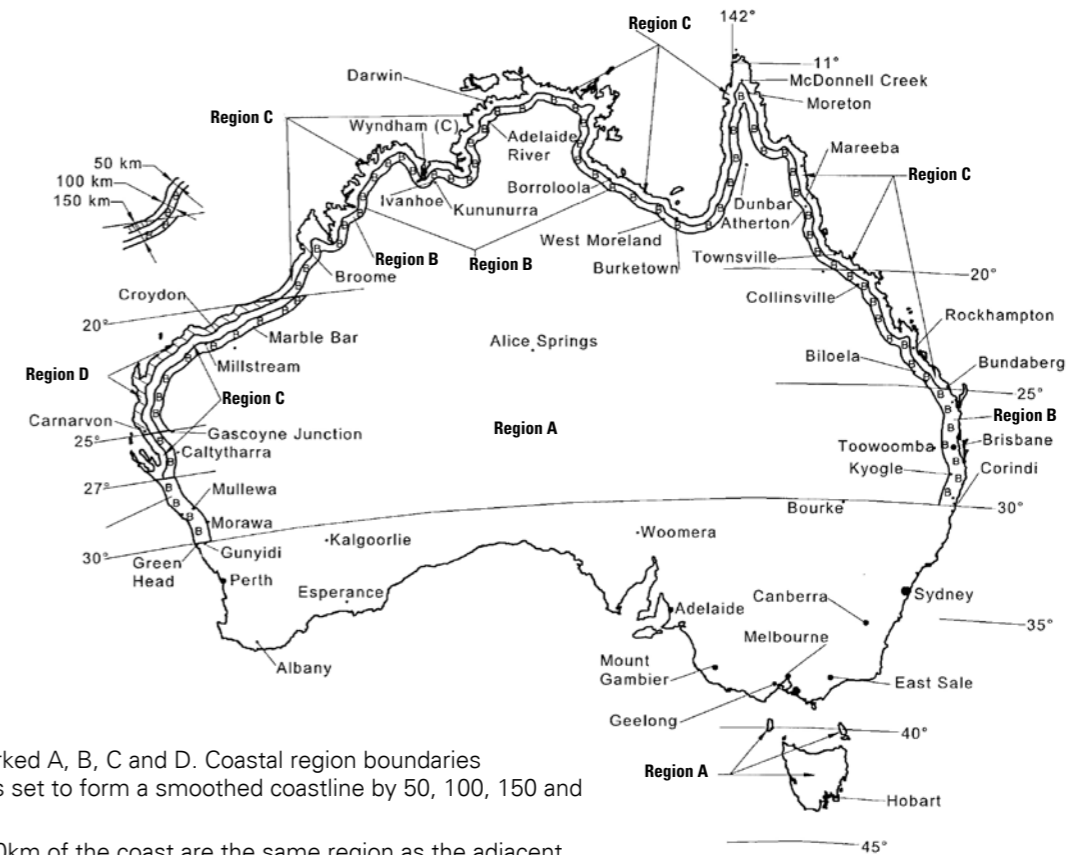

Notes.

Regions are marked A, B, C and D. Coastal region boundaries are smooth lines set to form a smoothed coastline by 50, 100, 150 and 200km.

Islands within 50km of the coast are the same region as the adjacent coast. High wind areas also exist outside the wind regions indicated on the above map. Uni-Pier Australia Pty Ltd advise that verification be sought from a Structural Engineer or local council.

**Wind Classification System - from wind region map and site conditions**

**Legend**

- FS = full shielding
- PS = partial shielding
- NS = no shielding
- N = non-cyclonic
- C = cyclonic
- N/A = not applicable - beyond the scope of Uni-Pier design
- TC = terrain category

Terrain Category (this a guide only of category classification that surrounds or is likely to surround the site with 5 years)

- 3 Level wooded country, suburban buildings
- 2.5 Lightly wooded, long grass (600mm), some buildings
- 2 Rough, open water surfaces, isolated trees
- 1 Flat natural surface

Notes describing Topographic Class are a guide only. Site specific advice should be sought from a Structural Engineer.

Wind region (from map)	TC	Wind class														
		Topographic class														
		T1 Flat areas, slopes less than 1:10, lower third of any hill, middle third of hill less than 1:5			T2 Sloping ground greater than 1:5 and less than 1:3			T3 Sloping ground greater than 1:3			T4 Top of slope less than 1:3			T5 Top of steep hill greater than 1:3		
		FS	PS	NS	FS	PS	NS	FS	PS	NS	FS	PS	NS	FS	PS	NS
A	3	N1	N1	N1	N2	N2	N2	N2	N3	N3	N2	N3	N3	N3	N3	N4
	2.5	N1	N1	N2	N2	N3	N3	N2	N3	N3	N3	N3	N4	N4	N4	N4
	2	N1	N2	N2	N2	N3	N3	N3	N3	N3	N3	N4	N4	N4	N4	N4
B	3	N2	N2	N3	N3	N3	N4	N3	N4	N4	N4	N4	N4	N4	N5	N5
	2.5	N2	N3	N3	N3	N4	N4	N3	N4	N4	N4	N4	N5	N4	N5	N5
	2	N2	N3	N3	N3	N4	N4	N4	N4	N5	N4	N5	N5	N5	N5	N6
C	3	C1	C1	C2	C2	C2	C3	C2	C3	C3	C3	C3	C3	C3	C4	C4
	2.5	C1	C2	C2	C2	C3	C3	C3	C3	C3	C3	C4	C4	C4	C4	N/A
	1,2	C2	C2	C2	C2	C3	C3	C3	C4	C4	C3	C4	C4	C4	N/A	N/A
D	3	C2	C3	C3	C3	C4	C4	C3	C4	C4	C4	N/A	N/A	N/A	N/A	N/A
	2.5	C2	C3	C3	C3	C4	C4	C4	N/A	N/A	C4	N/A	N/A	N/A	N/A	N/A
	1,2	C3	C3	C4	C4	C4	N/A	N/A	C4	N/A	N/A	N/A	N/A	N/A	N/A	N/A

**Important Note. Uni-Pier products are designed for general construction (ie residential). Uni-Pier Australia Pty Ltd recommend that advice be sought from a Structural Engineer especially when wind zones would typically include N6, C3 and C4.**



# The Superior Support for all Off-Ground Flooring

## UNI-PIER BUILDERS GRADE - 65 x 65 x 2mm POSTS

Adjustable Screw Top Head (STH) WITH Antcap

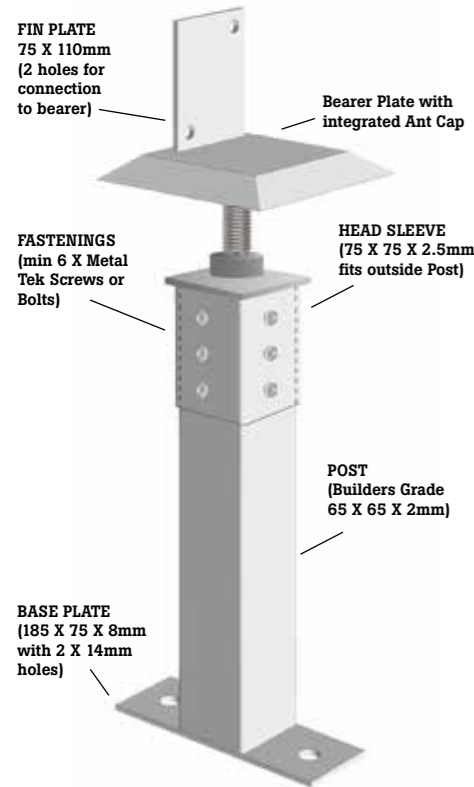

Telescopic Adjustable Head WITH Antcap

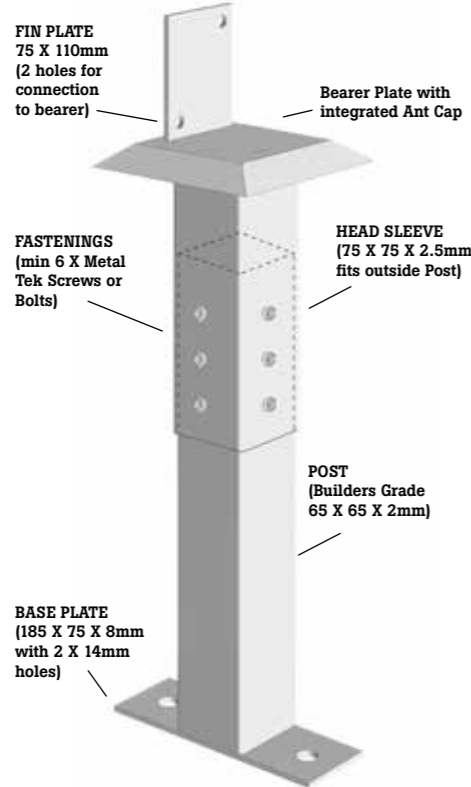

Telescopic Adjustable Head WITHOUT Antcap

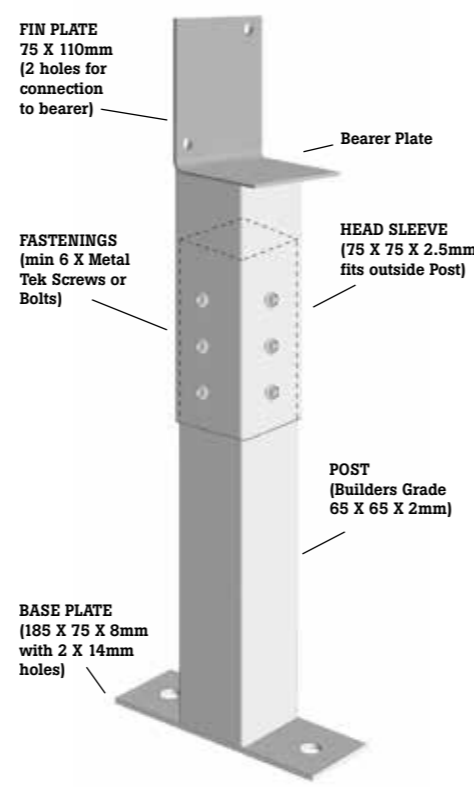

## UNI-PIER HEAVY GRADE - 75 x 75 x 2.5mm POSTS

Adjustable Screw Top Head (STH) WITH Antcap

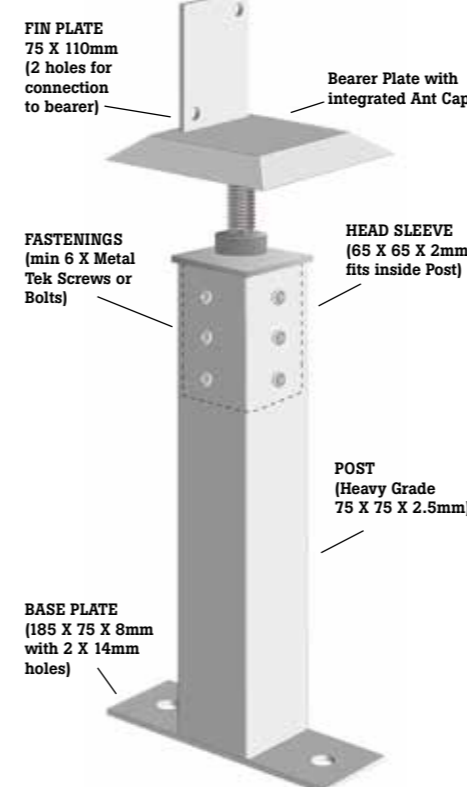

Telescopic Adjustable Head WITH Antcap

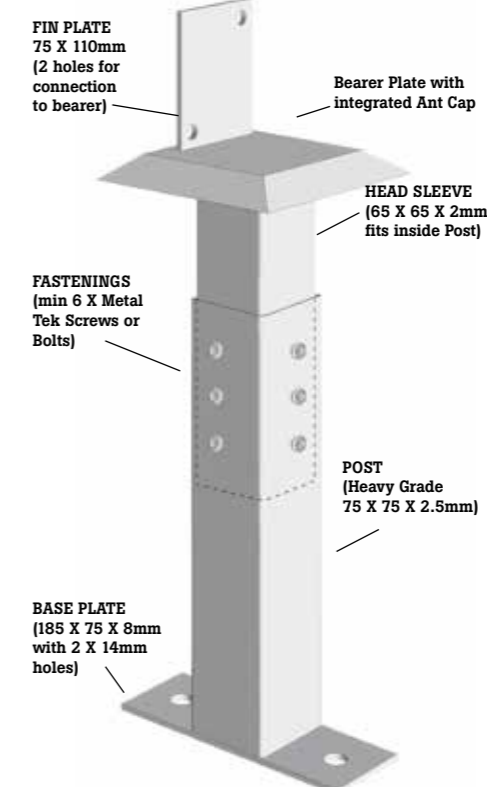

Telescopic Adjustable Head WITHOUT Antcap

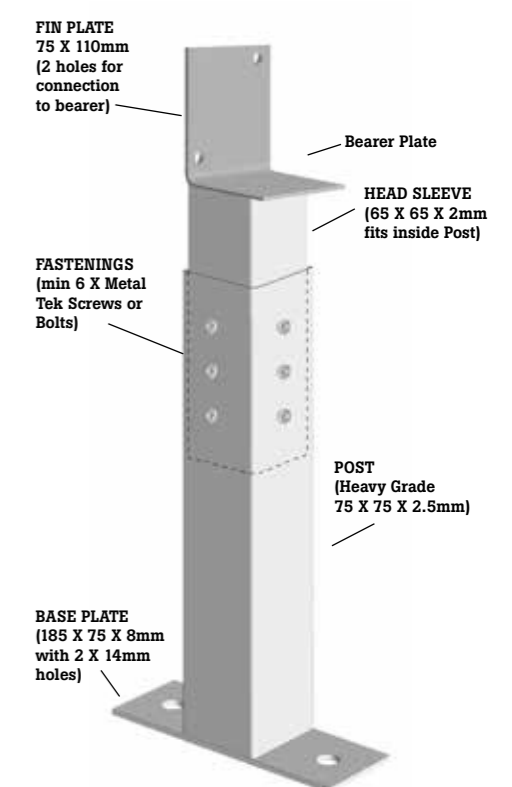

Also available with 200 X 200 X 10mm Baseplate

Uni-Pier are a two (2) Part system comprised of a Uni-Pier Head assembly (with or without integrated antcap\* and fin plate) and a Uni-Pier Post (with integrated base plate).

Our most common grades available and two types of Heads (Telescopic or STH) available.

1. Builders Grade 65 x 65mm x 2mm Uni-Pier Post
2. Heavy Grade 75 x 75mm x 2.5mm Uni-Pier Post

Also available in Extra Heavy (75 x 75 x 4mm), Mega Grade (89 x 89 x 2, 3.5 or 5mm), Light Super Mega Grade (100 x 100 x 3mm) & Super Mega Grade (100 x 100 x 4mm).

Refer [www.unipier.com.au](http://www.unipier.com.au)

### TELESCOPIC ADJUSTABLE HEAD\*

The Uni-Pier Telescopic Head provides the adjustment. The Uni-Pier Telescopic Head slides over the top of the Uni-Pier Post for Builders Grade and slides inside the Uni-Pier Post for Heavy Grade.

The Uni-Pier Telescopic Head provides you with up to 200mm of adjustment. The Uni-Pier Head Sleeve is 300mm in length and is designed so that you have a minimum of 100mm of overlap in order to secure the Uni-Pier Head assembly to the Uni-Pier Post with Self Drilling, Self-Tapping Metal TEK screws. We recommend a minimum of six (6).

### UNI-PIER ADJUSTABLE SCREW TOP HEAD (STH)

The Uni-Pier Adjustable Screw Top Head (STH) works in exactly the same way as the Uni-Pier Telescopic Head. The difference is that the sleeve is 200mm in length and the 200mm worth of adjustability is shared between 100mm of Telescopic Adjustment + 100mm of Screw Adjustment - simply by the turning of the nut. As the Sleeve is just 200mm in length, the minimum height actually attained by a Uni-Pier 200mm Post and STH Head combination is 255mm.

Eg: 200mm Post + STH = 255mm to 455mm adjustability  
400mm Post + STH = 455mm to 655mm adjustability and so on.

### HOW THEY WORK

The rule is to select a Uni-Pier Post which is the closest to the underside of your desired height. Uni-Pier Posts start at 200mm and increase in length of 200mm increments ie 200mm, 400mm, 600mm, 800mm etc and continue this way to 4000mm (for Builders Grade) and 5000mm (for Heavy Grade). If your desired height is say 950mm, then you would select the 800mm Uni-Pier Post and the Uni-Pier Head would be adjusted up 150mm to reach your desired height.

If it were 1195mm, then you would select the 1000mm Uni-Pier Post and adjust the Uni-Pier Head accordingly to reach your desired height.

**NB. Telescopic System:** If your desired height is less than 300mm then cutting of the Uni-Pier Head Sleeve will be required. Remember the Uni-Pier Head Sleeves are 300mm in length therefore the minimum height is in fact 300mm.

**NB. STH System:** If your desired height is less than 255mm then cutting of the Uni-Pier Head Sleeve and Post will be required.

Remember to coat the exposed metal with either a cold gal or 2 part epoxy.

\* Also available without Antcap

### SPECIFIED FASTENINGS TO AFFIX UNI-PIER HEADS TO POSTS

Minimum (6) six screws: 14-20x22 Class 4. (Builders Grade and Heavy Grade only). Recommend Buildex® self-drilling, self-tapping Metal TEKs®.

Bolts: (2) two x 100 x 12mm (up to Extra Heavy Grade) OR (2) two x 120 x 12mm (Mega Grade and above) Hot Dipped Galvanised bolts, nuts and washers.



## UNI-PIER EXTRA HEAVY GRADE - 75 x 75 x 4mm POSTS

Adjustable STH WITH Antcap

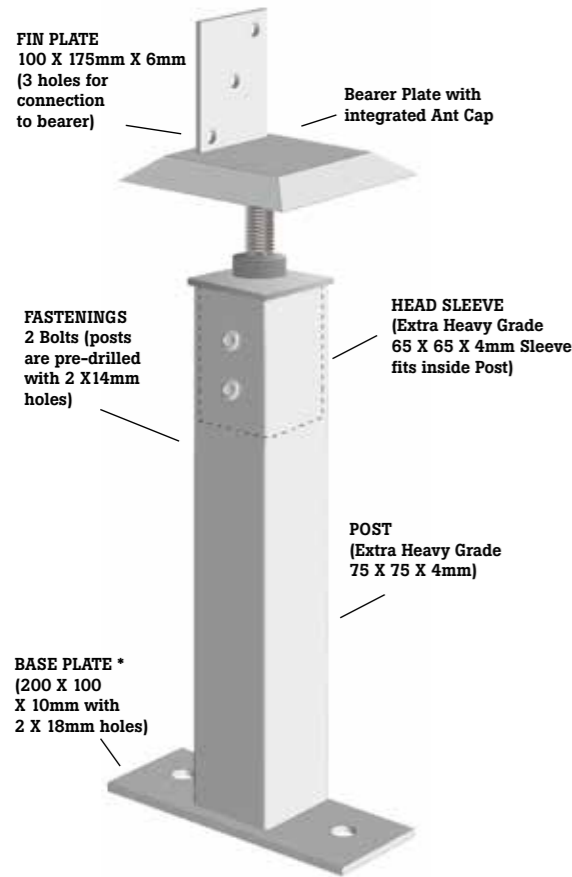

Adjustable STH WITHOUT Antcap

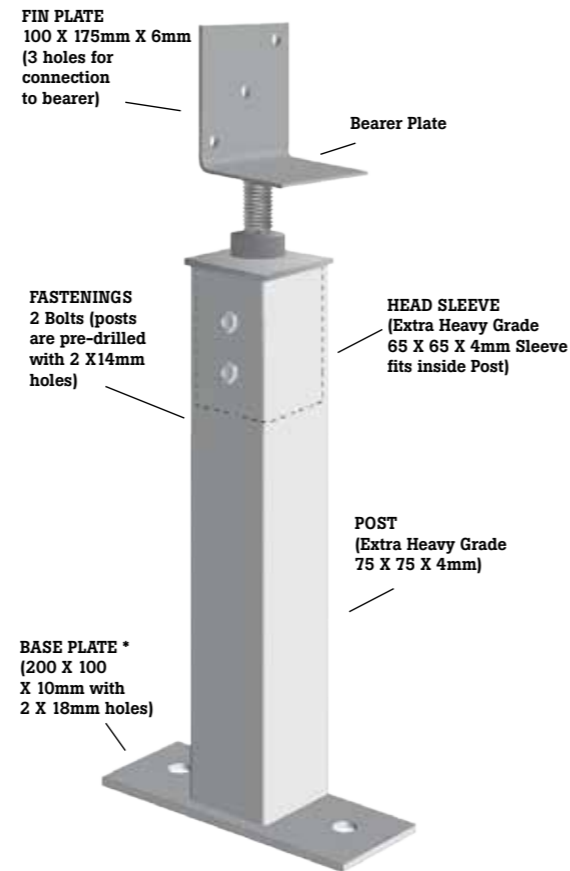

Adjustable Telescopic Head WITH Antcap

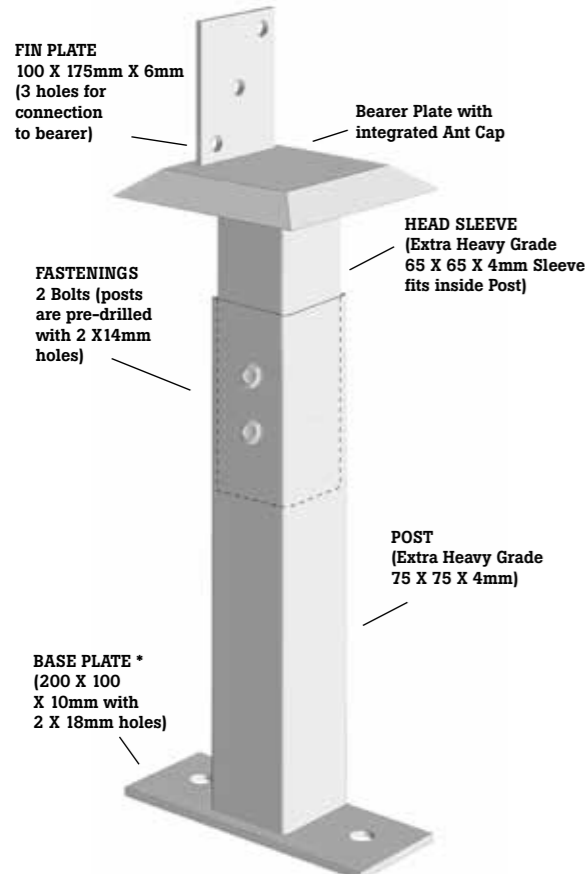

Telescopic Adjustable Head WITHOUT Antcap

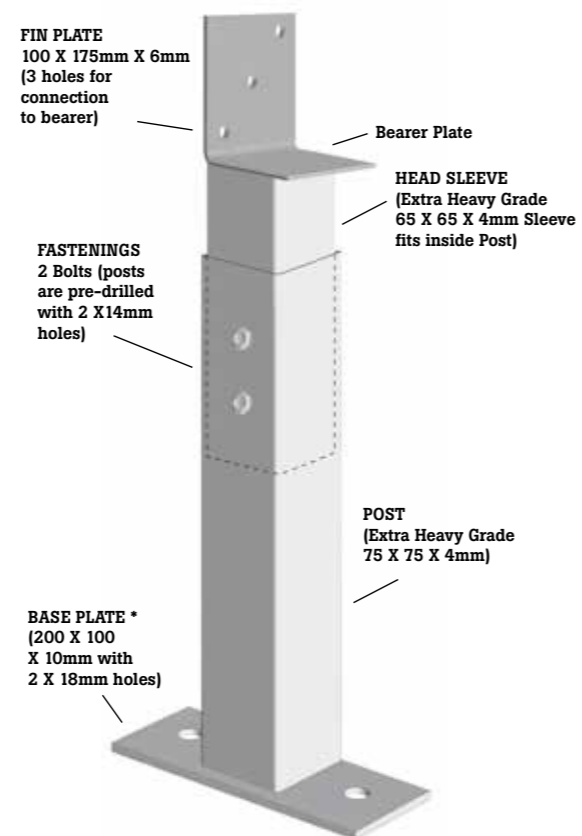

\* BASE PLATE also available in 200 X 200 X 10mm with 4 X 18mm holes



## UNI-PIER MEGA GRADE - 89 x 89mm POSTS. Available in 2,3.5 & 5mm wall thickness

Adjustable Screw Top Head (STH) WITH Antcap

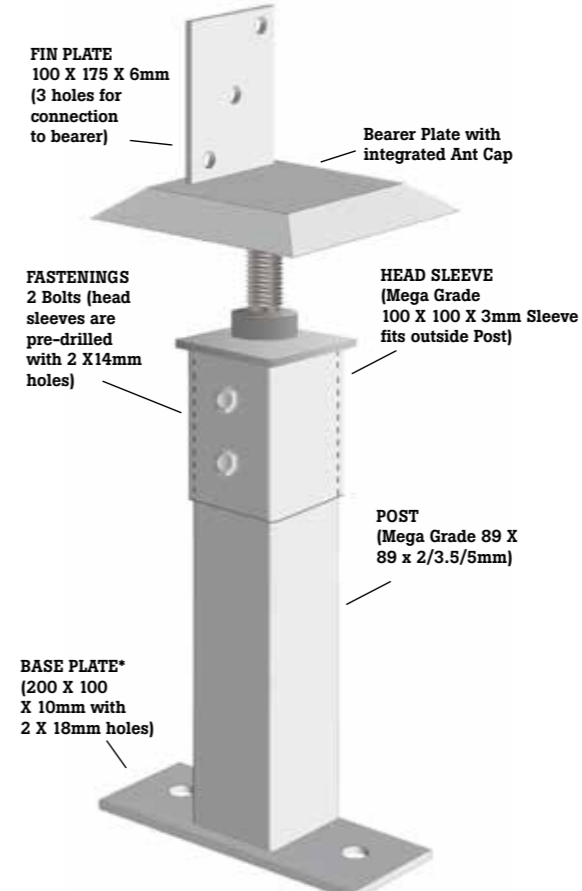

Adjustable Screw Top Head (STH) WITHOUT Antcap

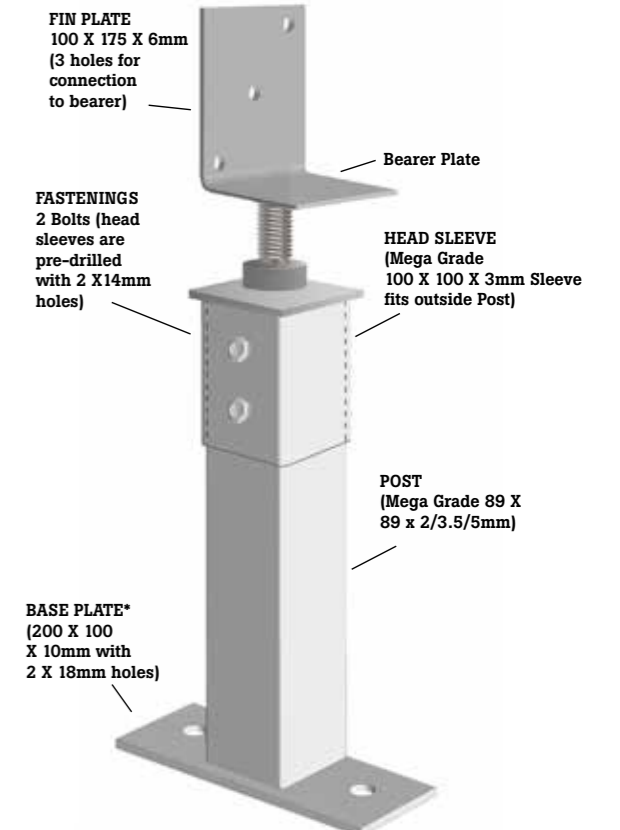

Telescopic Adjustable Head WITH Antcap

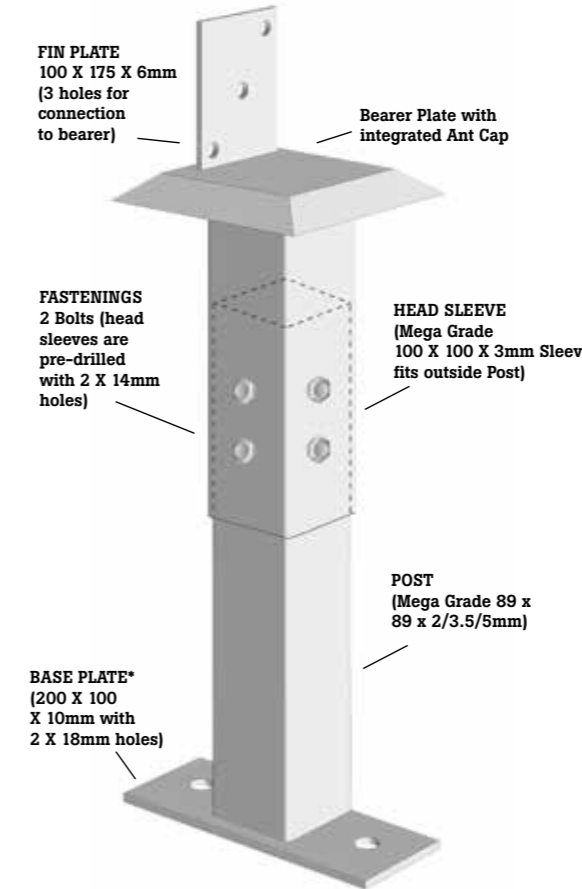

Telescopic Adjustable Head WITHOUT Antcap

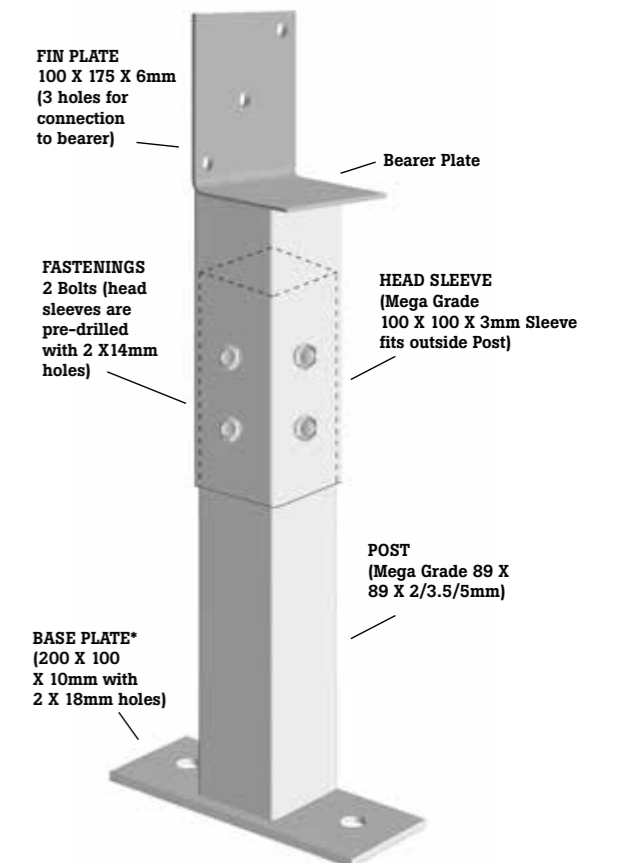

\* BASE PLATE also available in 200 X 200 X 4mm with 4 X 18mm holes



## UNI-PIER LIGHT SUPER MEGA GRADE - 100 X 100 X 3mm POSTS

Adjustable Screw Top Head (STH) WITH Antcap

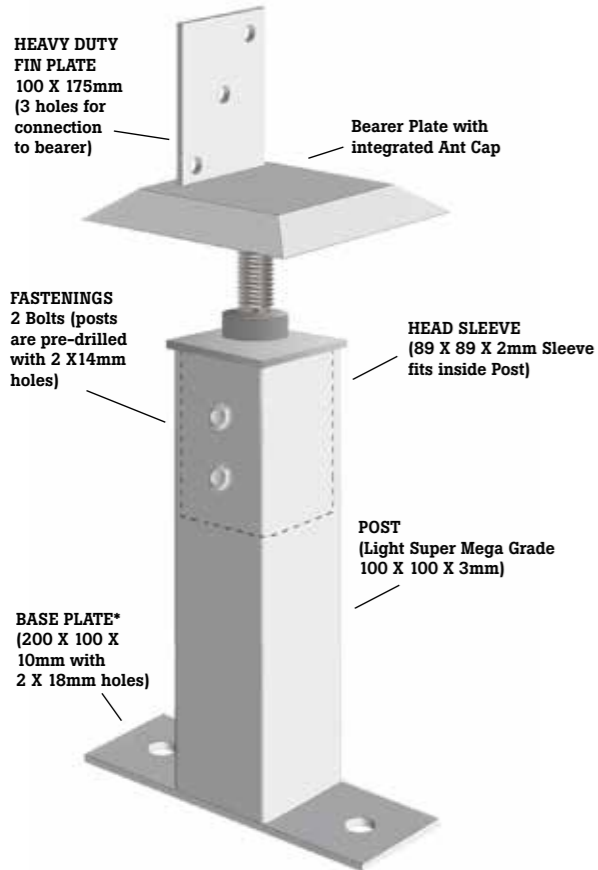

Adjustable Screw Top Head (STH) WITHOUT Antcap

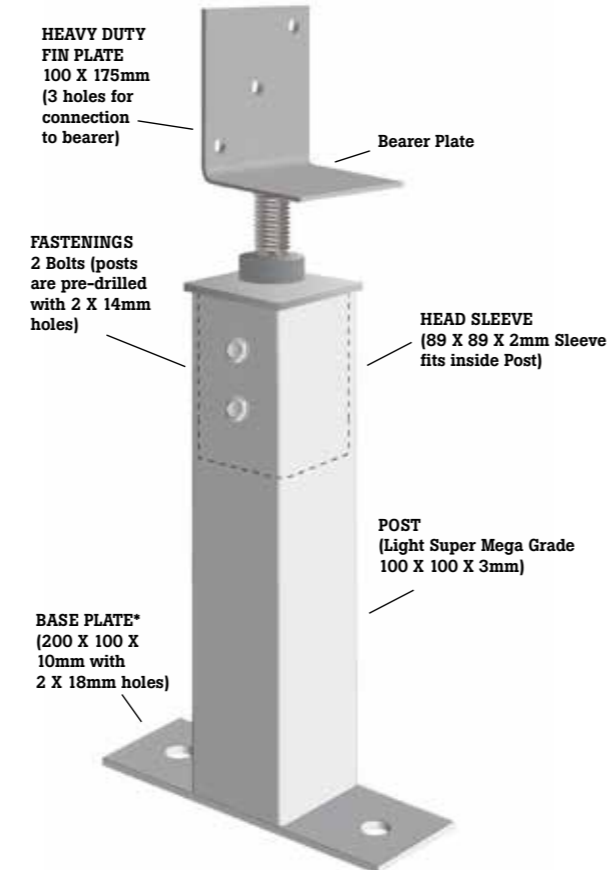

Telescopic Adjustable Head WITH Antcap

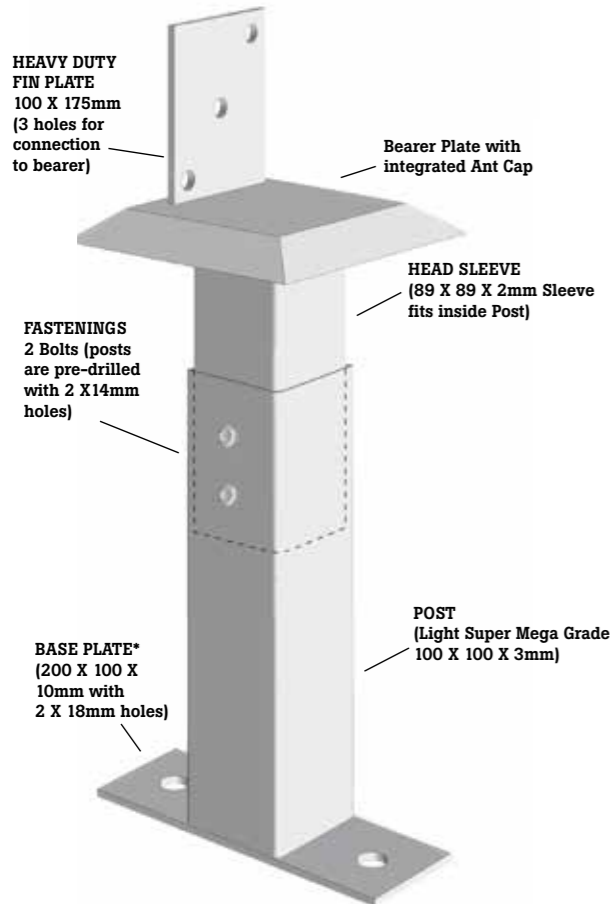

Telescopic Adjustable Head WITHOUT Antcap

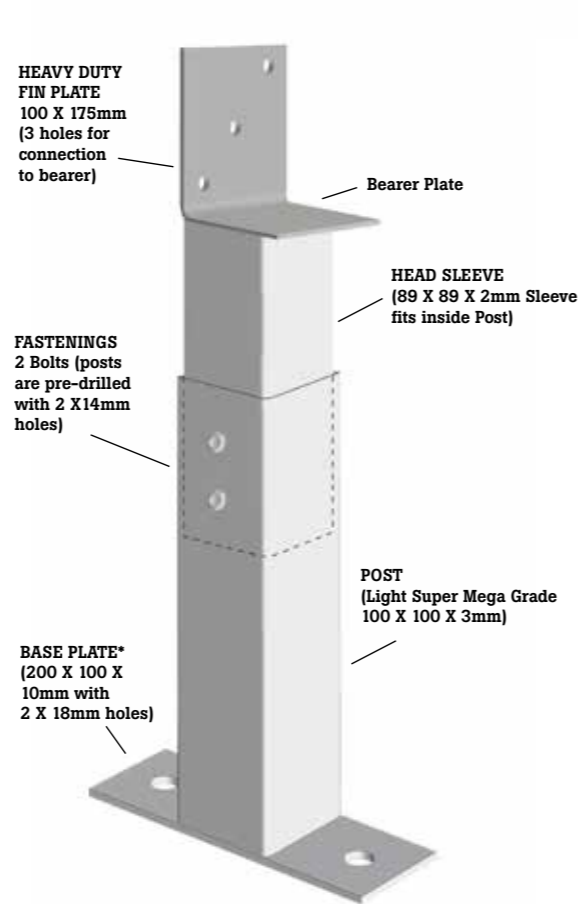

\* BASE PLATE also available in 200 X 200 X 10mm with 4 X 18mm holes

## UNI-PIER SUPER MEGA GRADE - 100 X 100 X 4mm POSTS

Adjustable Screw Top Head (STH) WITH Antcap

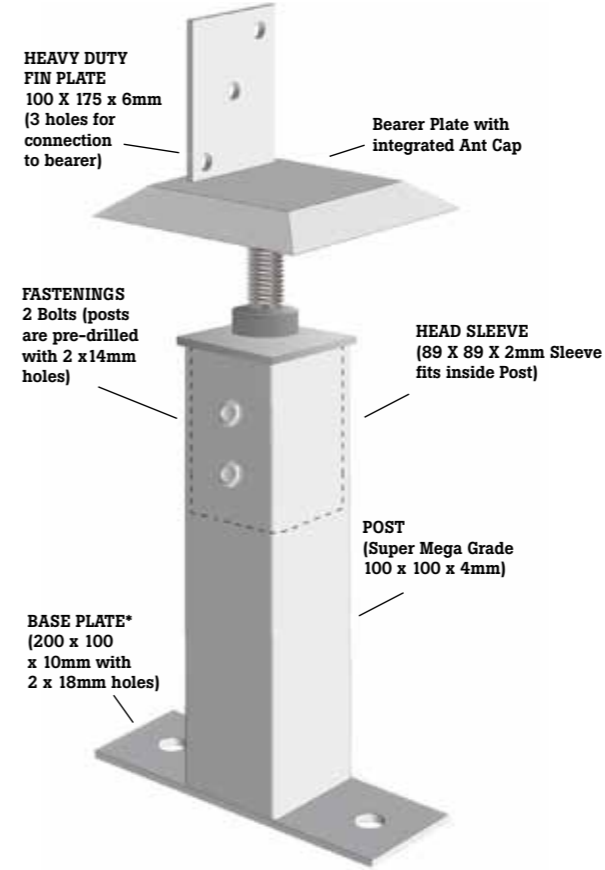

Adjustable Screw Top Head (STH) WITHOUT Antcap

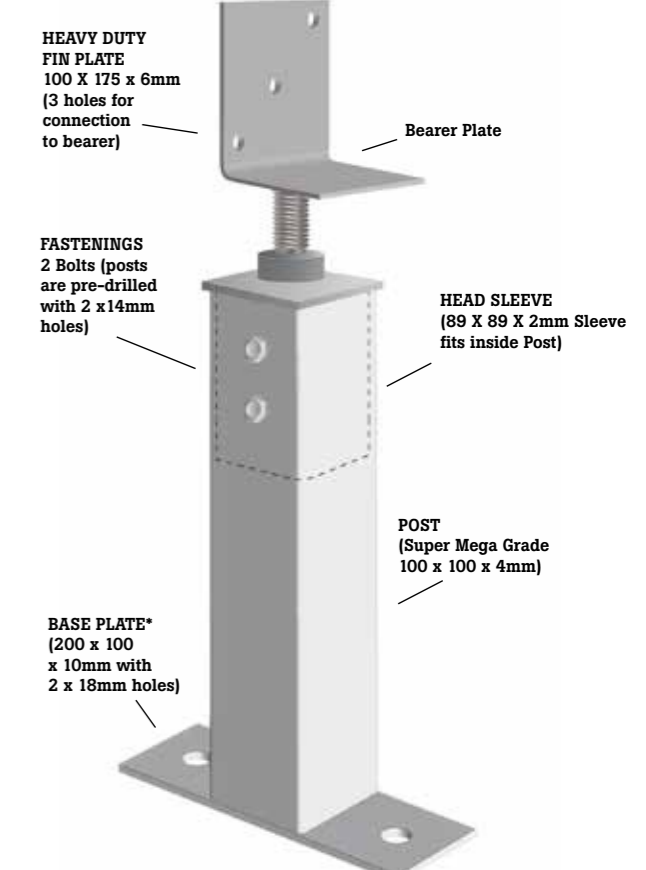

Telescopic Adjustable Head WITH Antcap

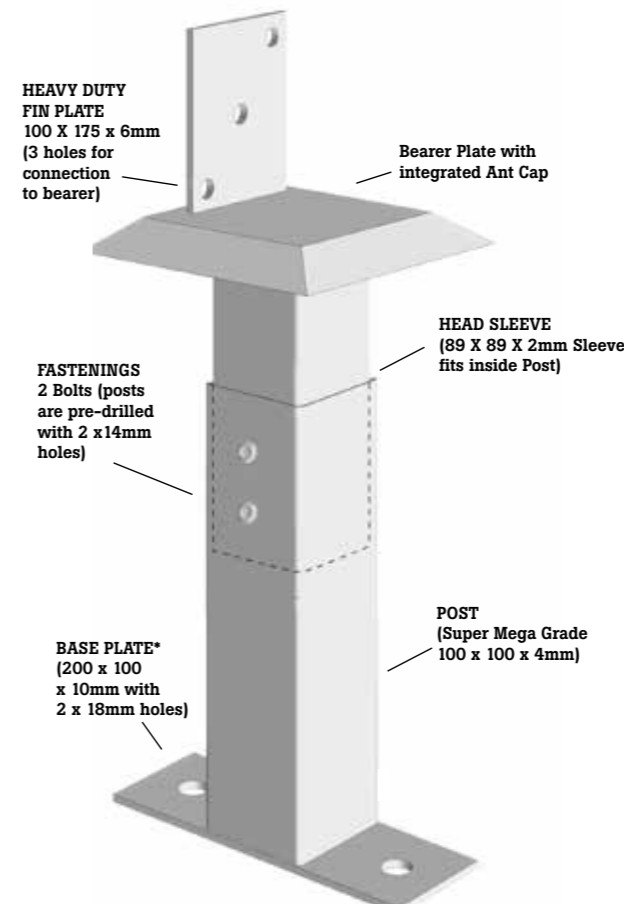

Telescopic Adjustable Head WITHOUT Antcap

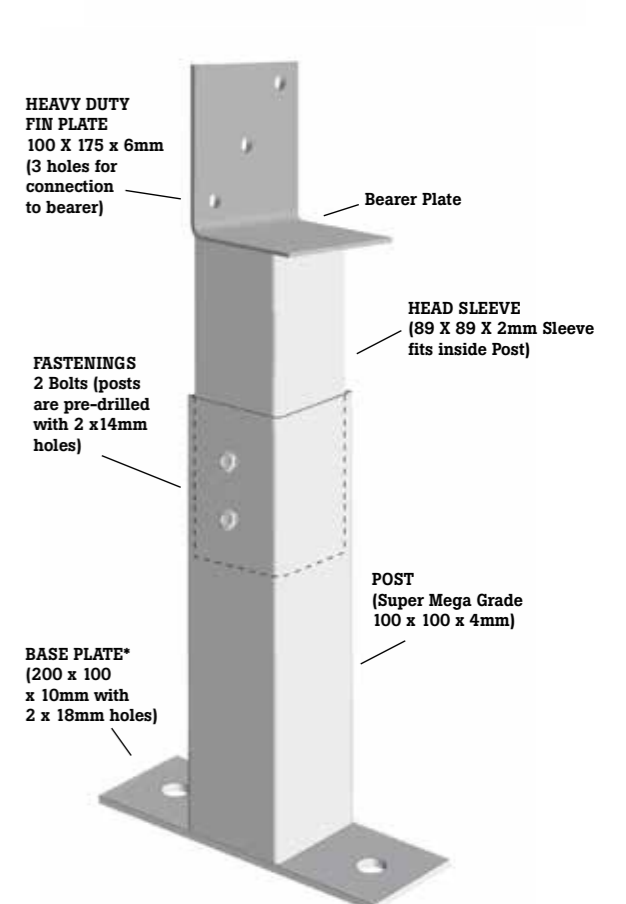

\* BASE PLATE also available in 200 x 200 x 10mm with 4 x 18mm holes



## Sub Floor Bracing using Uni-Brace®

Uni-Pier developed a bracing system that is pre-assembled, convenient, easy to adjust on site and requires no cutting. The only tools required for installation are a power drill with driver bits capable of installing Metal TEK or 14 – 20x22 or Series 500 to AS3566 Class 4 self-drilling and tapping screws into steel and clamps to hold the assembly in position during installation. For timber posts use Type 17 Wood TEK screws.

Further information including installation recommendations, can be found in the Uni-Brace® brochure downloaded from [www.unipier.com.au](http://www.unipier.com.au), or available from your Uni-Pier supplier.

The tables below apply to Uni-Brace being installed sub-floor between Uni-Piers to a maximum height of 3.6m and for single storey houses. Uni-Braces® are available in four nominal sizes from 900mm to 1800mm.

	UBR9	UBR12	UBR15	UBR18
Nominal Supplied Length	900mm	1200mm	1500mm	1800mm
Minimum Extension	1640mm	1940mm	2240mm	2540mm
Maximum Extension	2100mm	3300mm	4500mm	5700mm

## Uni-Brace® Selection Table

To further assist selection, the following table can also be used as a guide to determine Uni-Brace® size requirements. This table assumes that posts to be braced are on level ground and are the same height.

		MAXIMUM POST SPACING (GRID)												
		1.2	1.5	1.8	2.1	2.4	2.7	3.0	3.3	3.6	3.9	4.2	4.5	4.8
MAXIMUM POST HEIGHT	0.6	N/A	N/A	UBR9	UBR12	UBR12	UBR12	UBR12	UBR15	UBR15	UBR15	UBR15	UBR15	UBR18
	0.9	N/A	UBR9	UBR9	UBR12	UBR12	UBR12	UBR12	UBR15	UBR15	UBR15	UBR15	UBR18	UBR18
	1.2	UBR9	UBR9	UBR12	UBR12	UBR12	UBR12	UBR12	UBR15	UBR15	UBR15	UBR15	UBR18	UBR18
	1.5	UBR9	UBR9	UBR12	UBR12	UBR12	UBR12	UBR12	UBR15	UBR15	UBR15	UBR15	UBR18	UBR18
	1.8	UBR12	UBR12	UBR12	UBR12	UBR12	UBR12	UBR12	UBR15	UBR15	UBR15	UBR15	UBR18	UBR18
	2.1	UBR12	UBR12	UBR12	UBR12	UBR12	UBR12	UBR12	UBR15	UBR15	UBR15	UBR15	UBR18	UBR18
	2.4	UBR12	UBR12	UBR12	UBR12	UBR12	UBR12	UBR12	UBR15	UBR15	UBR15	UBR15	UBR18	UBR18
	2.7	UBR12	UBR12	UBR12	UBR12	UBR12	UBR12	UBR12	UBR15	UBR15	UBR15	UBR15	UBR18	UBR18
3.0	UBR12	UBR15	UBR15	UBR15	UBR15	UBR15	UBR15	UBR15	UBR18	UBR18	UBR18	UBR18	UBR18	
3.3	UBR15	UBR15	UBR15	UBR15	UBR15	UBR15	UBR15	UBR15	UBR18	UBR18	UBR18	UBR18	UBR18	N/A
3.6	UBR15	UBR15	UBR15	UBR15	UBR15	UBR15	UBR15	UBR18	UBR18	UBR18	UBR18	UBR18	N/A	N/A

Allow to overlap post. Refer to Step 1.

## Uni-Brace® Quantity Table

The following table is to determine the number of Uni-Braces® required on each grid, assuming a single storey house and a maximum roof pitch of 35 degrees. Ensure that correct wind classification is applied.

Pier Spacing Grid Maximum	Wind Class* N1	Wind Class* N2	Wind Class* N3	Wind Class* N4
2.0m	1 Uni-Brace® every 2nd row	1 Uni-Brace® every 2nd row	1 Uni-Brace® every row	1 Uni-Brace® every row
3.0m	1 Uni-Brace® every 2nd row	1 Uni-Brace® every row	1 Uni-Brace® every row	2 Uni-Braces® every row
4.0m	1 Uni-Brace® every row	1 Uni-Brace® every row	2 Uni-Braces® every row	2 Uni-Braces® every row
4.8m	1 Uni-Brace® every row	2 Uni-Braces® every row	2 Uni-Braces® every row	3 Uni-Braces® every row

\* If unsure of wind classification consult a registered Structural Engineer.

NB: Bracing of Uni-Piers is not required in many situations where the base of a building is built with masonry walls, however, you should always consult a registered Structural Engineer.

## Sub Floor Bracing

### Uni-Brace or site specific bracing that may be designed and certified by a Structural Engineer.

Cross bracing must be used between Uni-Piers in both directions of the pier's grid pattern, with each direction being designed separately. For this application of bracing, Uni-Brace is recommended.

As a general rule of thumb, post heights > 600mm which are not surrounded by a masonry wall will require bracing. However, **We recommend that you seek advice from a Structural Engineer for the correct bracing requirements.**

The bracing is typically connected to Uni-Piers with a minimum of (2) two Self-drilling, Self-tapping, Metal TEK screws. These are 14 – 20x22 or Series 500 to AS3566 Class 4 at each end and located no more than 75mm from the top or bottom of the Uni-Pier. The intersection of the braces is fixed together with one screw. It is important that bracing shown on Elevation 1 (below) resists wind loads from Direction 2; and Elevation 2 resists wind loads from Direction 1. The tables contain herein apply for cross bracing between steel Uni-Piers up to 3.6m in height for single storey houses.

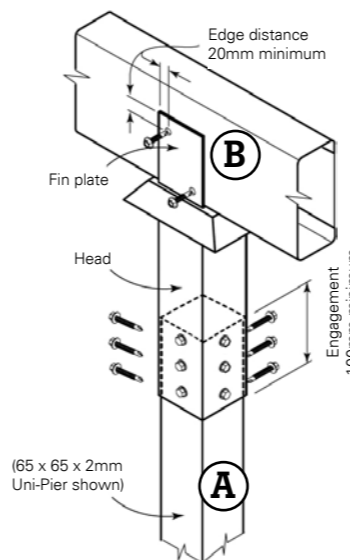
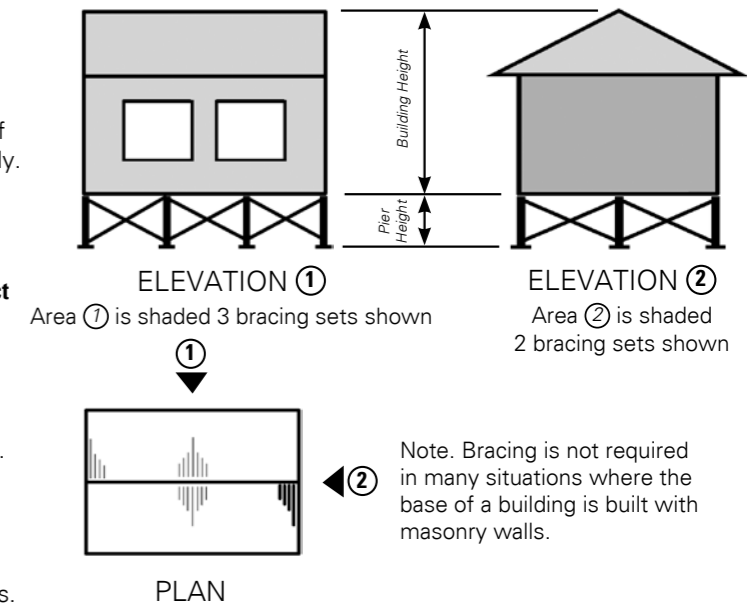

**Builders Grade Uni-Pier**  
(65 x 65 x 2mm post)

**A Suggested Head to post fasteners**  
A minimum of (6) six Self Tapping, Self Drilling, Galvanised, Class 4 Metal TEK Screws. Either 14–20 x 22 or Series 500.  
Or Bolts: (2) two 100 x 12mm Hot Dipped Galvanised c/w nuts & washers (up to Extra Heavy Grade) OR 2 x 120mm Hot Dipped Galvanised c/w nuts & washers (Mega Grade and above).

**B Suggested Fin plate to bearer fasteners**  
Screws for timber bearers: Type 17, 14–10 x 65 to AS 3566 Class 4  
Screws for steel bearers: Self Drilling, Self Tapping Screws, 14-20 x 22 or Series 500 to AS 3566 Class 4.  
Bolts: M12 galvanised mild steel with nuts and washers.  
For pier locations [1] and [5], in wind regions N3, N4, N5, C1 and C2 the number of fasteners is specified.

For all other situations use 2 screws or 2 bolts.

Note: Always consult your Structural Engineer for site specific details.

### Additional Guidelines

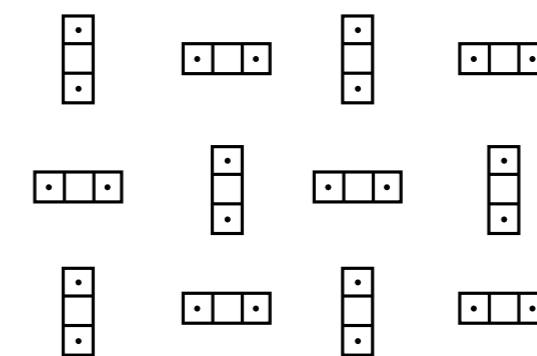

**Recommended Pier Orientation**  
alternate base plate direction for maximum pier stability

**Wind regions N1, N2 and N3**  
Two (M10) galvanised masonry anchors or two 12mm diameter x 125mm anchors.

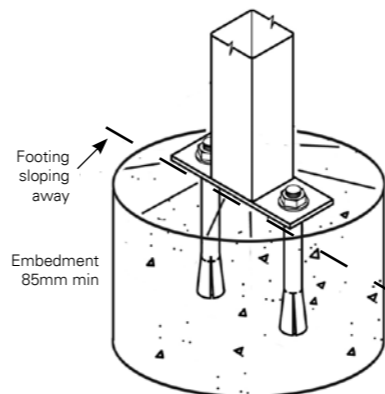

**Head Assembly**  
Joining bearers on Pier

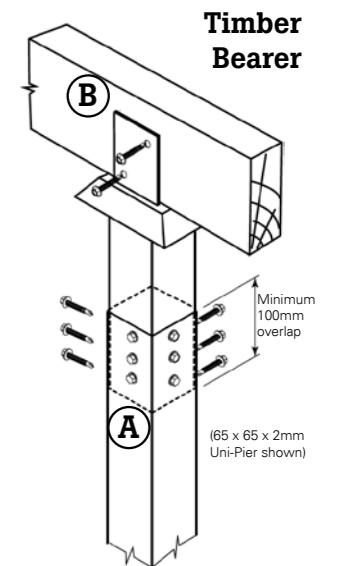

**Heavy Grade Uni-Pier**  
(65 x 65 x 2mm post)

**Wind regions N1, N2 and N3**  
(Uni-Pier to be cast in concrete)  
Footing must be designed by a geotechnical or Structural Engineer

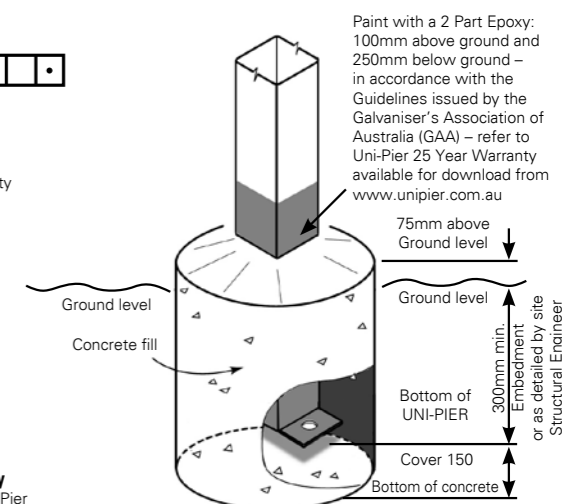

# Design Assumptions

1 Data is provided for seven wind regions in five groups according to AS 4055-2006 as follows:

AS4055	Equivalent to:
N1	W28N permissible W34N limit state
N2	W33N permissible W40N limit state
N3	W41N permissible W50N limit state
N4 & C1	W50N & W41C permissible W61N & W50 limit state
N5 & C2	W60N & W50C permissible W74N & W61C limit state

2 All brickwork supported on concrete footings.

3 Maximum height of wall is 3.0m.

4 Height from ground floor level to highest point on roof should not exceed 5.5m.

5 **No bracing** implies **masonry veneer** type of construction.

6 Allowed Design Loads

- Dead load of floor 0.5 kPa
- Live load of floor 1.5 kPa (for internal areas)
- Live load of floor 3.0 kPa (for external areas eg verandahs)
- Tile and Sheet roofs are considered
- Live load on roof 0.25 kPa
- Allowance made for stud walls lined with plasterboard

7 Maximum roof pitch is 35 degrees.\*

8 Capacity tables are based on assumption that piers are spaced the same in both directions. (ie X=Y in Pier Location Diagram).

\*Or as designed by a Structural Engineer.

I hereby certify that the Uni-Pier Technical Manual 2022 including its design tables, bracing details and connection details as well as other information contained therein, has been prepared in accordance with the relevant Australian Standards and the Building Code of Australia. The Uni-Pier Selection Guide can only be applied for the use and installation of actual Uni-Pier products.



Trevor Hall, FIE Aust. CPEng RPEQ 5081  
**KNEEBONE, BERETTA & HALL PTY. LTD.**  
 Consulting Engineers

## Caution

Uni-piers are generally designed for residential applications, including roof and floor loads.

Where buildings have large "point loads" or where buildings are of an unusual structural design, Uni-Pier Australia Pty Ltd recommend that advice be sought from a registered practising Structural Engineer.

Construction near salt water and in areas of high salinity will require piers and braces to be protected by a suitable coating. Site welding of any floor family members is NOT recommended.

All concrete footings to be finished at a sufficient height above ground line so as to prevent any run off water, or soil, coming in contact with steel posts. A height of 75mm is recommended.

If in doubt, always consult a registered practising Structural Engineer.

This manual was prepared to comply with the relevant Australian Standards and contains technical information for the design for flooring of residential structures and to be applied by a registered practising engineer. Uni-Pier Australia Pty Ltd reserves the right to revise or amend this manual without notice.

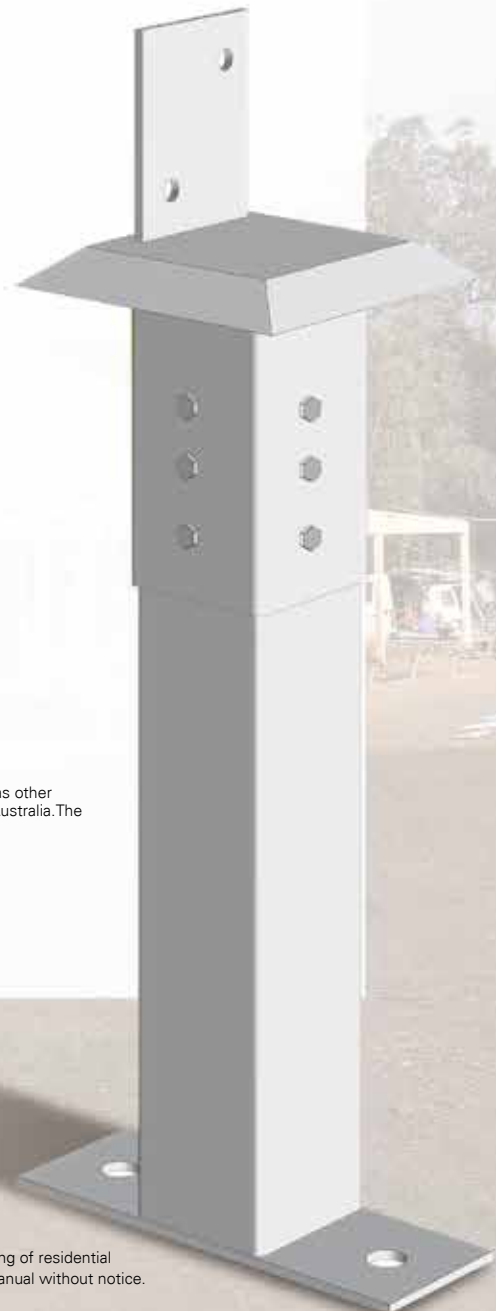

**FOR MORE INFORMATION CONTACT:**  
**Uni-Pier Australia Pty Ltd** ACN 131 900 546  
 1300 366 362  
[www.unipier.com.au](http://www.unipier.com.au)

Copyright. The material in this publication is published by and is the property of Uni-Pier Australia Pty. Ltd. and may not be reproduced in any form without the written permission of the publisher. This product shall perform as specified if used in accordance with the recommendations provided by Uni-Pier Australia Pty. Ltd. Information in this publication is correct at the time of printing but is subject to change without notice.

